



Installation procedures

Wall protections & handrails

Spm[®]
wall protection

NOTES

CONTENTS

PROTECTION RAILS AND PLATES

4/10

1. Tools required	4
2. IMPACT and LINEA'PUNCH NEO protection rails	4
3. CONTACT protection plates	9
4. DECOBOWL plate	9
5. ELASTO'PUNCH protection rails	10
6. Maintenance	10

PANELS

11/23

1. Tools required	12
2. Conditions for installation	12
3. Fixing DECOCHOC panel	13
4. Installation procedure	15
5. DECOCHOC panel maintenance	23
6. Restrictions	23

CORNER PROTECTORS AND INDIVIDUAL PROTECTION

24/31

1. Tools required	24
2. Corner protectors on aluminium core: CORNEA, CORNEAFLEX and COMBO'CORNER	25
3. Adhesive corner protectors: PROFILA 30/50, PROTECTA 2, PROFIL'INOX 30/50, LINEA'FLEX	28
4. ELASTO'FLEX corner protector	30
5. SAFY'CORNER AND SAFY'DOOR individual protection	30
6. Maintenance	31

HANDRAILS

33/59

1. Tools required	33
2. Methods for fixing handrails	33
3. Installation procedure	33
4. ESCORT handrails	35
5. LINEA'TOUCH and TOUCH+ handrails	41
6. STARLINE handrails	45
7. ESCORT'DUO and LINEA'DUO handrails	48
8. PERFORMER 2 handrails	51
10. Internal, external and made-to-measure angle pieces	55
11. Adjustment shim for ESCORT, STARLINE, LINEA'TOUCH and TOUCH+ handrails	56
12. Laying handrails with the service duct kit	56
13. Installing curved handrails	58
14. Maintenance	59

IMPORTANT:

We are continuously making technical improvements to our products; before starting any work, our customers should check with us that this document is still in force. The installation company must comply with applicable regulations at the time of signing the contract. Examine the materials prior to installation to ensure that there are no visible defects. If the product has already been installed, the cost of any remedial work will not be covered. The information in this document is valid from 1 November 2023 and is subject to change without prior notice.

INSTALLING IMPACT AND LINEA'PUNCH NEO

1. TOOLS REQUIRED	4
2. IMPACT AND LINEA'PUNCH NEO PROTECTION RAILS	4/8
2.1 Installation procedure for IMPACT and LINEA'PUNCH NEO protection rails	5
2.1.1 Preparation and cutting method	6
2.1.2 Fixing the protection rails	6
2.2 Joining IMPACT and LINEA'PUNCH NEO protection rails	8
3. CONTACT PROTECTION PLATES	9
3.1 Installation procedure for CONTACT protection plates	9
4. DECOBOWL PLATE	9
4.1 Installation procedure for DECOBOWL plate with SPM acrylic glue	9
4.2 Installation procedure for DECOBOWL plate with SPM MS Polymer glue	9
5. ELASTO'PUNCH PROTECTION RAILS	10
5.1 Installation procedure for ELASTO'PUNCH protection rails	10
6. MAINTENANCE	10

1. TOOLS REQUIRED

- Mitre saw with carbide blade for aluminium and PVC
 - Mallet
 - Measuring tape and pencil
 - Laser level
 - Level and ruler
 - Electric drill and screwdriver
 - Pressure roller
- Reference: ROMUS 94959
- Reference: ROMUS 93290
- Reference: SPM OUTRM004

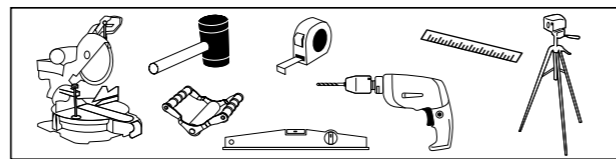

2. IMPACT AND LINEA'PUNCH NEO PROTECTION RAILS

- SPM IMPACT and LINEA'PUNCH NEO wall protection rails consist of a PVC profile mounted on aluminium rails or brackets.
 - Protection rails are finished with end pieces.
 - These protections must be screwed to the wall.
- The table below shows the fixing techniques to be used for the main types of wall surface found in the building industry.

TYPE OF WALL	FIXING PROCEDURE
WALLS WITH WOODEN STUDS	Woodscrews, 5 x 40 mm
METALLIC STRUCTURES	Self-tapping screws, 5 x 40 mm
PLASTERBOARD - SINGLE SKIN AND DOUBLE SKIN (*)	Self-tapping expansion plugs or metal expansion plugs
HOLLOW BRICK, HOLLOW BREEZE BLOCK, HOLLOW PLASTER TILES (**)	5-mm diameter countersinking screws (length according to wall type)
CONCRETE WALLS	Metal expansion plugs
SOLID BRICK AND OLD WALLS	FISCHER-type plugs, 6 x 35 mm diameter for 5 x 50 mm screws
CELLULAR CONCRETE	FISCHER-type plugs, 6 x 35 mm diameter for 5 x 50 mm screws

(*) If the area is subject to heavy traffic, add an extra wood or metal stud in the partition.

(**) If using Molly-type metal plugs, remove the head of the plug with a plier.

2.1 INSTALLATION PROCEDURE FOR IMPACT AND LINEA'PUNCH NEO PROTECTION RAILS

IMPACT

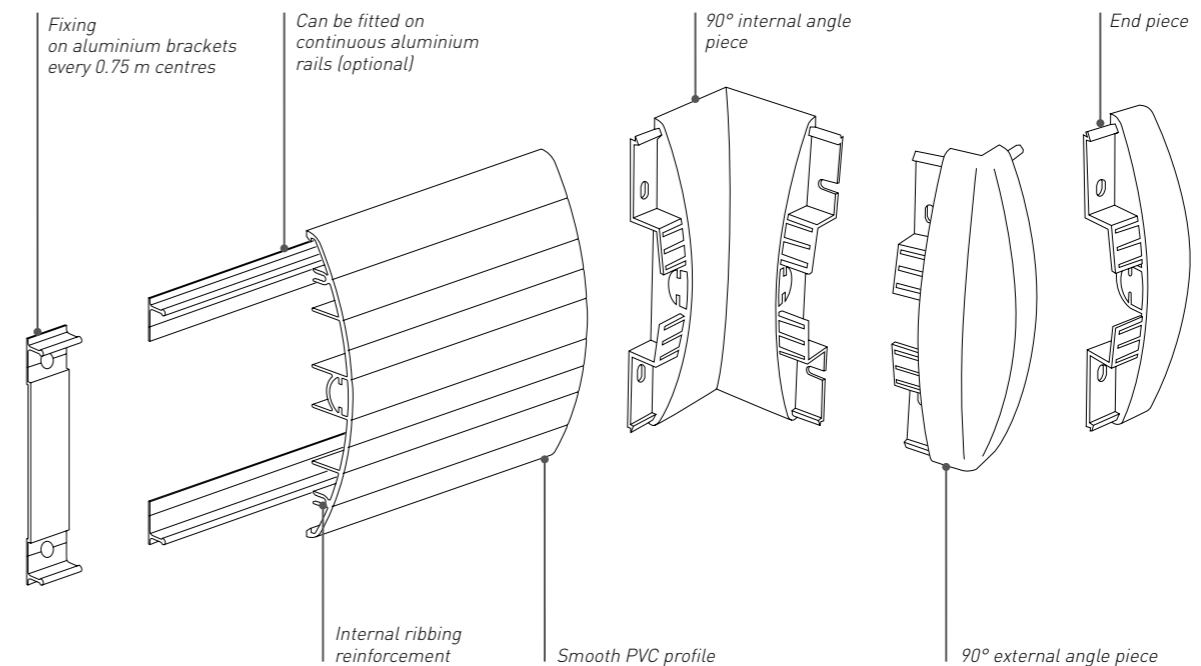

LINEA'PUNCH NEO

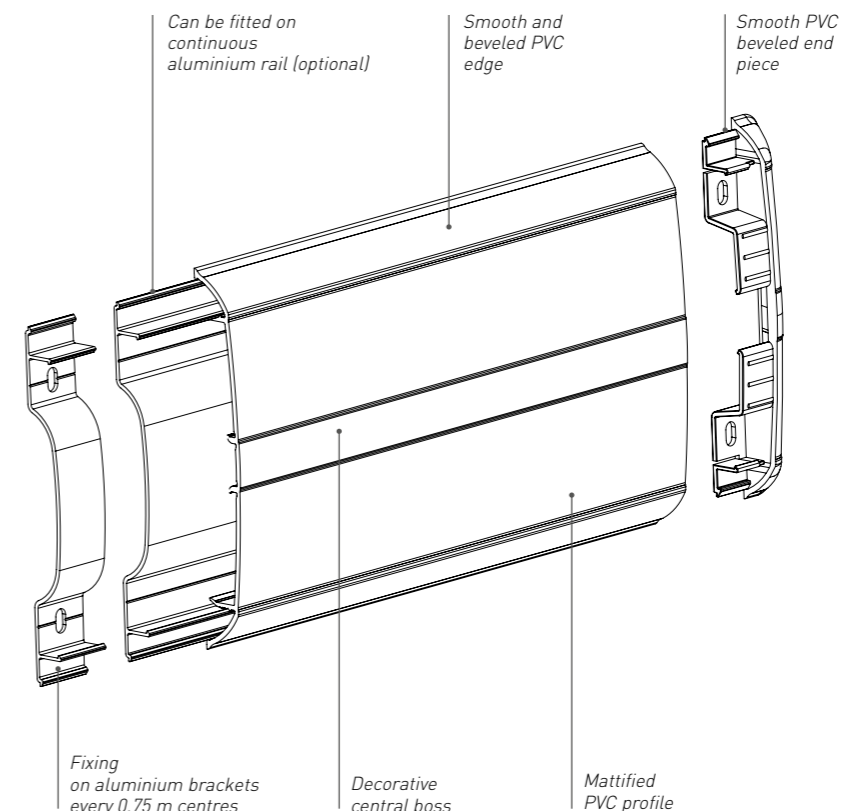

INSTALLING IMPACT AND LINEA'PUNCH NEO

2.1.1. PREPARATION AND CUTTING METHOD

• When the profiles have to be cut in advance, the table below shows the dimensions that need to be subtracted from the wall dimensions for cutting the PVC profile. For LINEA'PUNCH NEO, you are advised to use a batten to prevent the profile from bending and thereby ensure a straight cut.

! Caution: the lengths of the aluminium rail and the PVC profile are not the same.

IMPACT

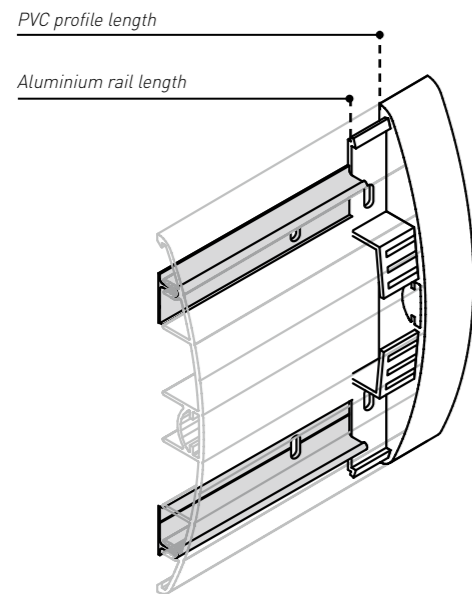

LINEA'PUNCH NEO

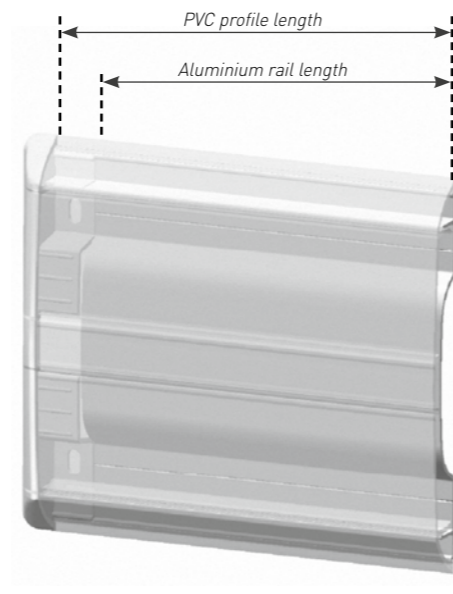

Length to be subtracted for each accessory [for PVC profiles]

PROTECTION RAILS	END PIECE	EXTERNAL ANGLE PIECE	INTERNAL ANGLE PIECE
IMPACT 200	50 mm	25 mm	65 mm
IMPACT 120	50 mm	20 mm	65 mm
IMPACT 60	50 mm	20 mm	65 mm
LINEA'PUNCH NEO	16.5 mm	-	-

• The length of the aluminium rail is then calculated by subtracting 40 mm from the length of the PVC profile.

2.1.2. FIXING THE PROTECTION RAILS

	LOW LEVEL PROTECTION	MID LEVEL PROTECTION
RECOMMENDED HEIGHT OF PROTECTION (RAIL CENTRELINE)	200 mm above floor level	800 mm above floor level
Use a pencil or laser level to draw upper and lower drilling centrelines along the wall.		
IMPACT 200	260 and 140 mm	860 and 740 mm
IMPACT 120	230 and 170 mm	830 and 770 mm
IMPACT 60	209.5 and 190.5 mm	809.5 and 790.5 mm
LINEA'PUNCH NEO	257 and 143 mm	857 and 743 mm

• To ensure that protection rails are fitted tightly against the wall, plug heads can either be embedded in the wall or removed to prevent excess thickness between the bracket (or rail) and the wall.

INSTALLING IMPACT AND LINEA'PUNCH NEO

IMPACT

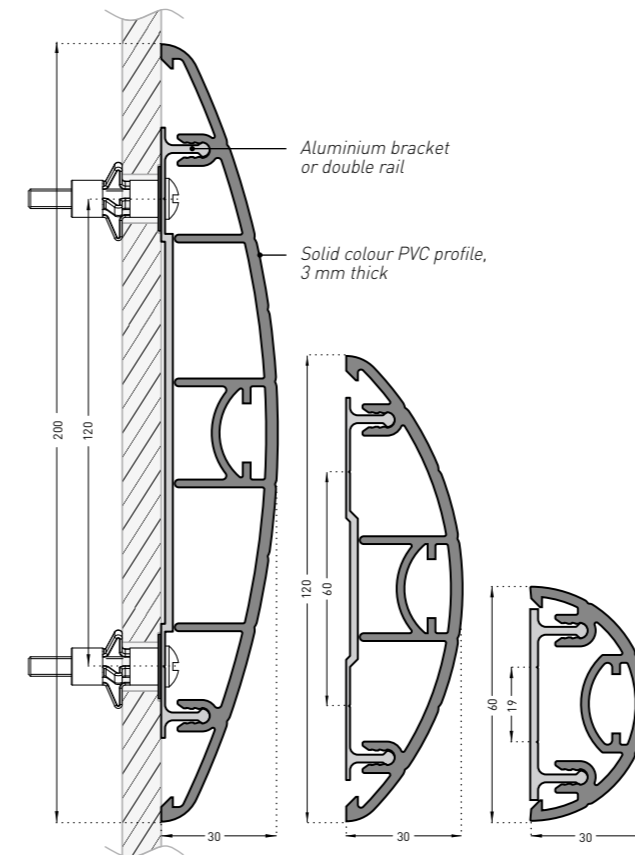

LINEA'PUNCH NEO

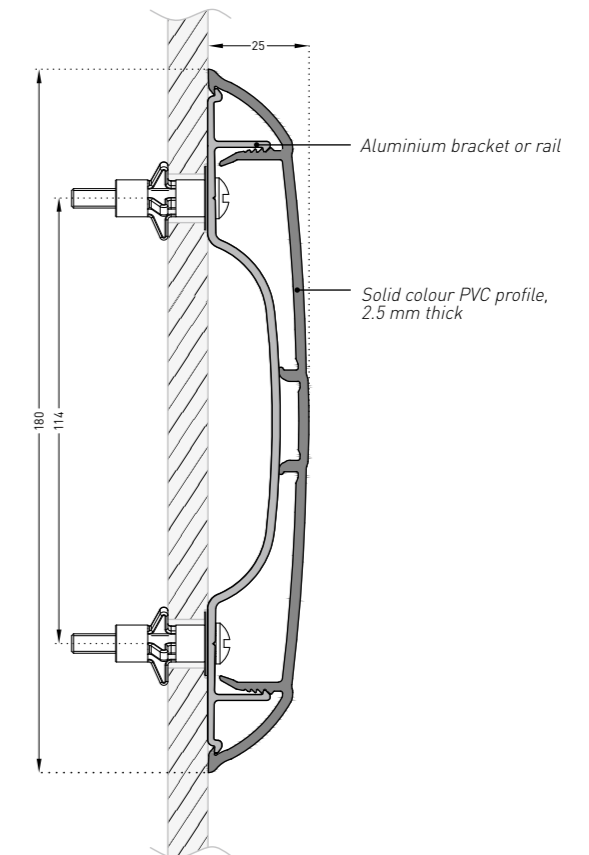

- Place the end pieces and internal / external angle pieces over the centrelines. Check that they are perpendicular to the floor and then mark their pre-drilled hole positions onto the wall.
- Drill into the wall, fit the plugs and then fix the end pieces and angle pieces onto the wall (see Fig. 1).

Option 1: Fixing on aluminium brackets

- Place the aluminium brackets over the centrelines. Place the first aluminium bracket approximately 20 mm from the end piece (or angle piece) and then space the brackets at intervals of no more than 750 mm. Check that they are perpendicular to the floor and then mark their pre-drilled hole positions onto the wall. Drill into the wall, fit the plugs and then fix all the aluminium brackets onto the wall (see Fig. 2).

Option 2: Fixing on IMPACT 120 and 200 double aluminium rails

- Measure the length between each end piece or angle piece and then cut the rail using a mitre saw. Drill through the rail along the grooves, starting at 20 mm from the edge and then spacing the holes at no more than 750 mm apart. Place the rails over the centrelines on the wall and then mark each hole on the wall. Drill into the wall, fit the plugs and then fix the rails onto the wall (see Fig. 3).

Option 3: Fixing on IMPACT 60 and LINEA'PUNCH NEO aluminium rails

- Measure the length between each end piece or angle piece and then cut the rail using a mitre saw. Drill through the rail along the grooves, starting at 20 mm from the edge and then spacing the holes at no more than 750 mm apart. Place the rails over the centrelines on the wall and then mark each hole on the wall. Drill into the wall, fit the plugs and then fix the rails onto the wall (see Fig. 4).

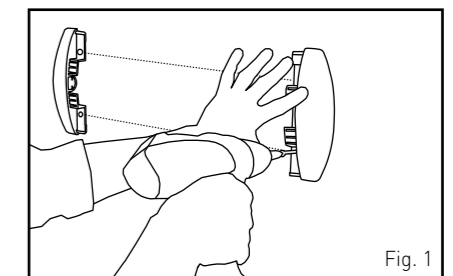

Fig. 1

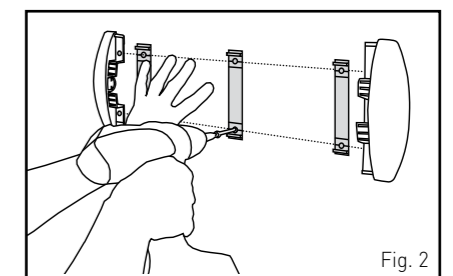

Fig. 2

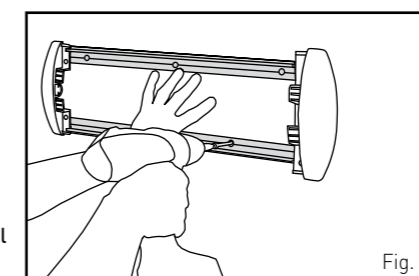

Fig. 3

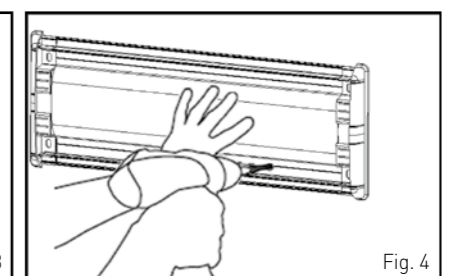

Fig. 4

! Caution: the lengths of the aluminium rail and the PVC profile are not the same.

INSTALLING IMPACT AND LINEA'PUNCH NEO

Irrespective of fixing options (brackets or rails):

- Measure the length from end piece to end piece, or from angle piece to angle piece, and then cut the PVC profile using a mitre saw. You are advised to use a template beneath the profile to ensure a straight cut and avoid deforming the profile.
- Clip the PVC profile onto the brackets or rails by striking it firmly. Use a mallet if necessary. Ensure that the PVC profile is correctly clipped on all the brackets or along the full length of the rail (see Fig. 5 and 6).
- The PVC profile is clipped onto the brackets or rail in four places. The two central zones allow the PVC profile to be gradually clipped in place, while enabling proper positioning and fitting with the end pieces. The outer clipping zones hold the profile firmly against the wall.
- Where the wall surface is uneven, you are advised to use fixing brackets at the start, middle and end of the uneven patch to force the profile to follow the wall's surface and thereby avoid excessively large clearances.
- Remove the protective film.

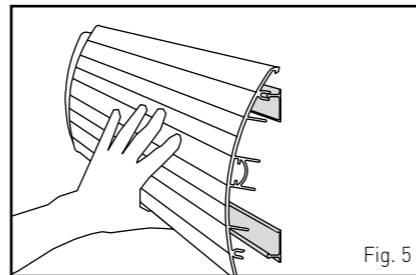

Fig. 5

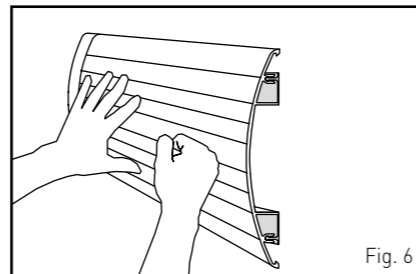
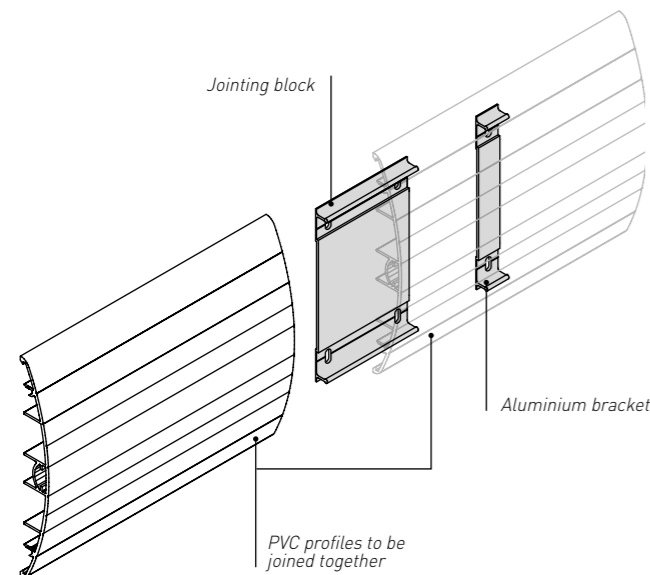

Fig. 6

2.2 JOINING IMPACT AND LINEA'PUNCH NEO PROTECTION RAILS

- For wall runs over 4,000 mm long, PVC protection rails mounted on brackets may be joined together using a 100 mm long aluminium piece to provide a continuity and hold the protection rail in place.
- These pieces (not pre-drilled) are fixed to the wall at four mounting points.

IMPACT



LINEA'PUNCH NEO

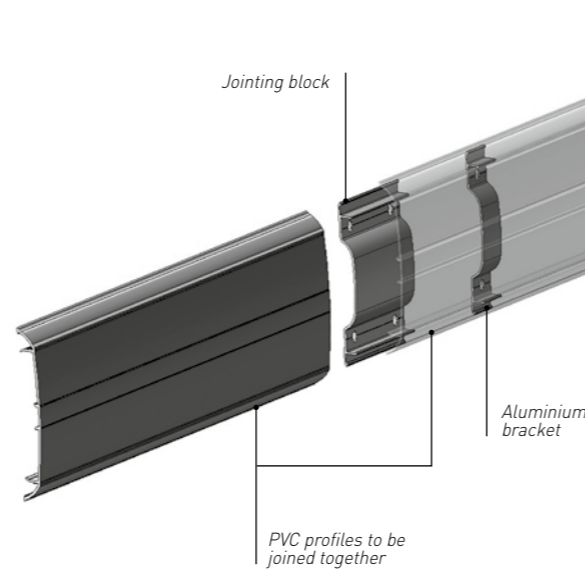

INSTALLING CONTACT AND DECOBOWL

3. CONTACT PROTECTION PLATES

- SPM CONTACT protection plates are wall protection solutions comprising a PVC profile 2.5 mm thick.
- These protections are fixed directly to the wall using SPM adhesive sealant.
- Adhesive foam tapes are laid along the edges (and in the centre for CONTACT 350) to temporarily hold the protection plate in place while the sealant dries (tack time). The adhesive foam tapes are in no way designed to provide permanent support.

3.1 INSTALLATION PROCEDURE FOR CONTACT PROTECTION PLATES

- Apply the SPM adhesive sealant to the surface of the PVC profile as shown in the diagram below:

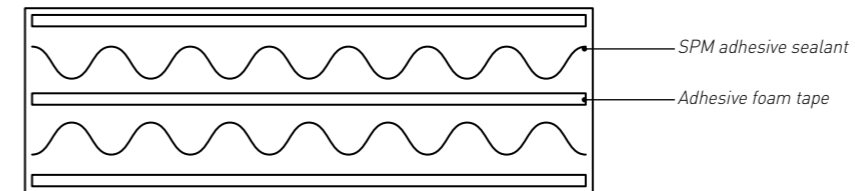

- Mark the height of the protection on the wall using a spirit level and a pencil (or laser).
- Remove the protective film from the adhesive foam tapes.
- Place the protection plate against the wall and take care to follow the drawn lines (once positioned on the wall, the protection plate cannot be moved).
- Press down hard (with a roller) all across the outer surface of the PVC profile.
- Clean off any excess sealant with a rag and hot water.
- Remove the protective film from the plates.

CONTACT

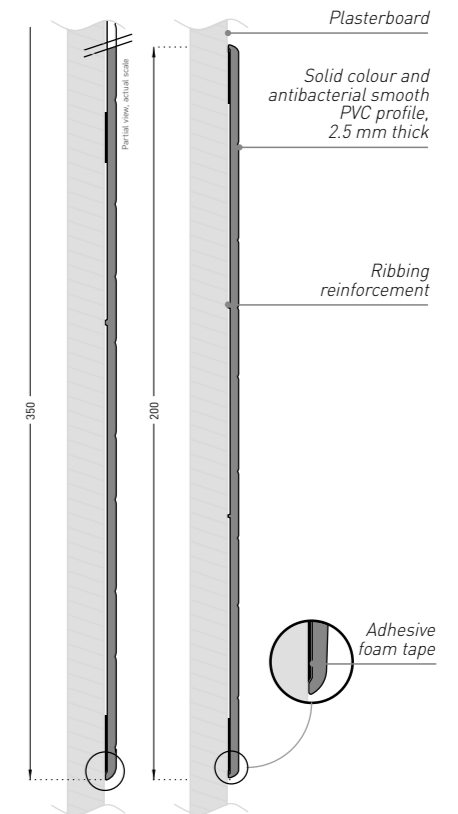

4. DECOBOWL PLATE

- The Decobowl plate consists of a pre-drilled PVC panel (straight or round shape), 2-mm thick. It is a solution of protection and reinforcement for wall hung toilet bowl to be fixed on a soft wallcovering.
- The Decobowl plate will have to jut out by 10 cm on the sides and above the bowl.

4.1 INSTALLATION PROCEDURE FOR DECOBOWL PLATE WITH SPM ACRYLIC GLUE

- Spread SPM acrylic glue over the wall surface which was marked out earlier.
- Please refer to section PANELS, Installing Decochoc, paragraph 4.3, page 16.
- The watertightness of the periphery of the plate is realized with silicone joint.

! It is imperative to allow an enough open time because of the acrylic glue trapped between two watertight surfaces

4.2 INSTALLATION PROCEDURE FOR DECOBOWL PLATE WITH SPM MS POLYMER GLUE

- Spread SPM MS Polymer glue over the wall surface which was marked out earlier.
- Please refer to section PANELS, Installing Decochoc, paragraph 4.4, page 16.
- The watertightness of the periphery of the plate is realized with silicone joint.

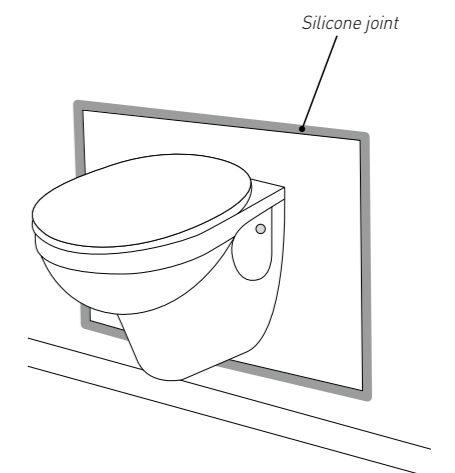

INSTALLING ELASTO'PUNCH

5. ELASTO'PUNCH PROTECTION RAILS

- Cut the protection rail to the required length. Use a circular saw or a wide-blade knife while constantly lubricating with water.
- Drill a hole in the profile at 100 mm from each end.

For Elasto'Punch 100D

- 25-mm diameter for the screw-cover blanking plug and washer
- 10-mm diameter for the screw
- Repeat approximately every 300 mm

For Elasto'Punch 200E

- 10-mm diameter for the screw. In each of the profile's grooves as shown in the diagram below
- Repeat approximately every 600 mm

- Mark the top edge of the protection rail from the floor (according to requirements)
- Use the protection rail as a template to mark and drill into the wall
- Choose the appropriate plug for the type of wall
- Fix to the wall using M7 socket screws with hexagonal or cylinder heads and fitted with a washer
- For Elasto'Punch 100D
 - Finish by gluing the end pieces and snapping in the screw-cover blanking plugs.

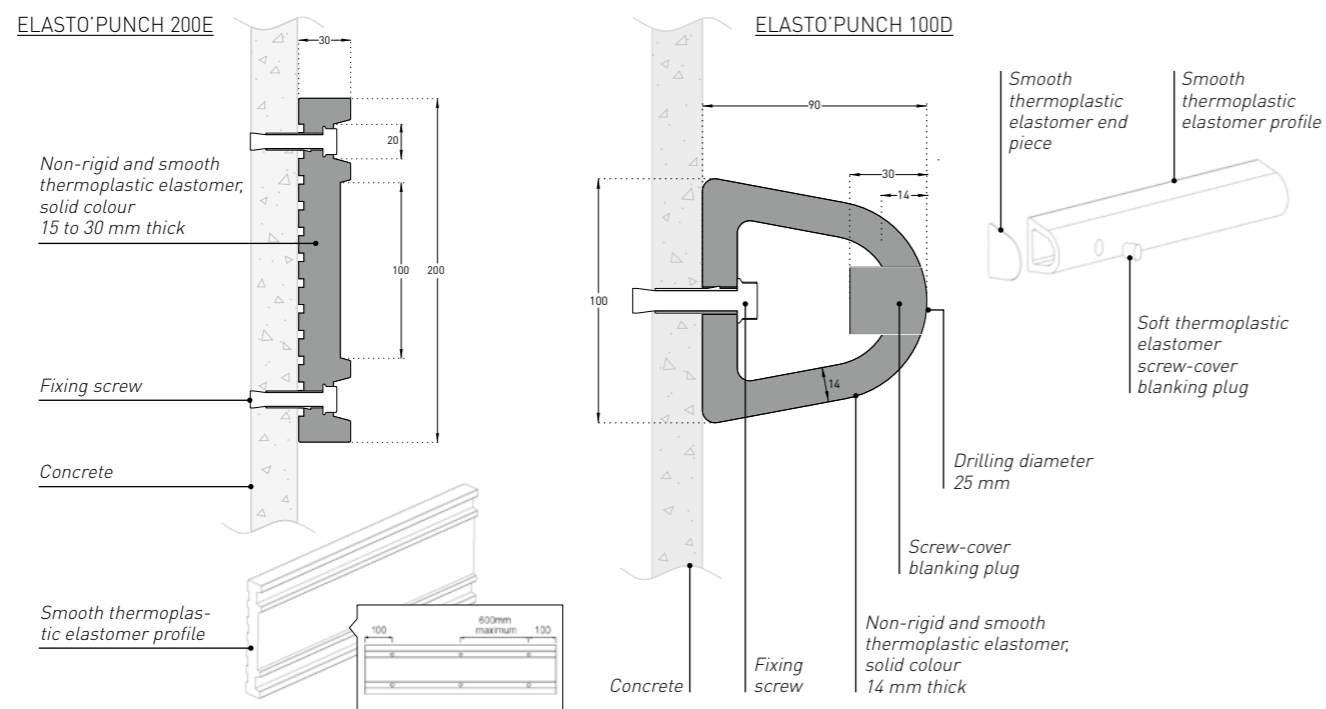

6. MAINTENANCE

- Do not leave products exposed to sunlight, that could lead to changes in colour and/or deform the product, due to excessive increases in temperature.
- It is essential to use solvents that do not leave any greasy or dry residue.
- The following products are recommended for cleaning:
 - Ammonia
 - Ethanol
 - Isopropyl alcohol
 - Essence F cleaner
 - Standard cleaning products, such as Bioquell and Anios
- Products **MUST NOT BE CLEANED** with a scouring pad, such as a Scotch-Brite pad.
- If using non-recommended products, test on an offcut. Reactions may differ depending on the colour of the product and the solvents used.

DO NOT USE:

- White spirit
- Acetone
- Petrol
- Paint thinners



PANELS

1. TOOLS REQUIRED

12

2. CONDITIONS FOR INSTALLATION

12

3. FIXING DECOCHOC PANELS

13/14

3.1 Information about SPM acrylic glue	14
3.2 Information about SPM Polymer glue	14
3.3 Information about SPM universal primer.....	14
3.4 Damp environments during installation.....	14
3.5 Damp environments after installation.....	15
3.6 Environments at low temperature	15

4. INSTALLATION PROCEDURE

15/23

4.1 Cutting and adjusting DECOCHOC panels	15
4.2 Installation method.....	15
4.3 Installation with SPM acrylic glue and fixing the DECOCHOC panels.....	16
4.4 Installation with SPM MS Polymer glue.....	16
4.5 Laying thermowelded joints	17
4.6 Laying silicone joints	17
4.7 Installing Fin'Color finishing and jointing profiles	18
4.7.1 Fixing the product	18
4.7.2 Cutting the product	18
4.7.3 Horizontal fitting.....	18
4.7.4 Vertical fitting	18
4.7.5 Combined horizontal and vertical fitting.....	18
4.8 Installing Fin'Alu finishing and jointing profiles.....	18
4.8.1 Fixing the product	19
4.8.2 Horizontal fitting.....	19
4.8.3 Combined horizontal and vertical fitting.....	19
4.9 Installing on round pillars.....	19
4.10 Installing DECOCHOC panels with bends for angles	20
4.11 Fitting DECOCHOC panels to doors	20
4.12 Fitting panels to door frames	22
4.13 Installing DECOPRINT panels	23

5. DECOCHOC PANEL MAINTENANCE

23

6. RESTRICTIONS

23

IMPORTANT: The information in this document is valid from 1 November 2023 and is subject to change without prior notice. We are continuously making technical improvements to our products; before starting any work, our customers should check with us that this document is still in force.



INSTALLING DECOCHOC

1. TOOLS REQUIRED

- Measuring tape and pencil
Reference: ROMUS 93290 and 93185
- Utility knife or SPM hook blade knife
Reference: SPM OUTCU001
- Stainless steel spreader with notched profile, type A2
Reference: SPM OUTCC001
- Circular saw with guide rail and carbide blade for aluminium / PVC for straight cuts and ripping
E.g. FESTOOL TS 55R - Blade reference TF48
- Pressure roller - *reference: SPM OUTRM004*
- SPM acrylic glue - *reference: SPM AC003SCO*
- SPM MS Polymer glue - *reference: SPM AC016SCO*
- SPM multipurpose adhesive sealant - *reference: SPM AC004SCO*
- SPM silicone joint - *reference: SPM JS000*
- LEISTER hot-air welding gun
Contained in the SPM OUTMS001 set
- Ultra speed welding nozzle for 4-5 mm rods - *Reference: ROMUS 95027*
Contained in the SPM OUTMS001 set
- Triangular ultra speed welding nozzle
Reference : ROMUS 095030
- Mitre shear cutter
- Triangular groover - *Reference: ROMUS 95185*
Contained in the SPM OUTMS001 set
- Mozart trimming knife - *Reference: ROMUS 95130*
Contained in the SPM OUTMS001 set
- Hole saw or precision saw (for notches, plug sockets, etc.)
- Retaining strap (for fitting on rounded walls and posts)
- Wood / PVC plane (for adjusting panels)
- PVC spatula (for removing excess glue)
- Non-residue solvent (grease or dry), such as ethanol, isopropyl alcohol and heptane
- Tack rags
- Laser level
- Humidity tester
- Multifunction tool

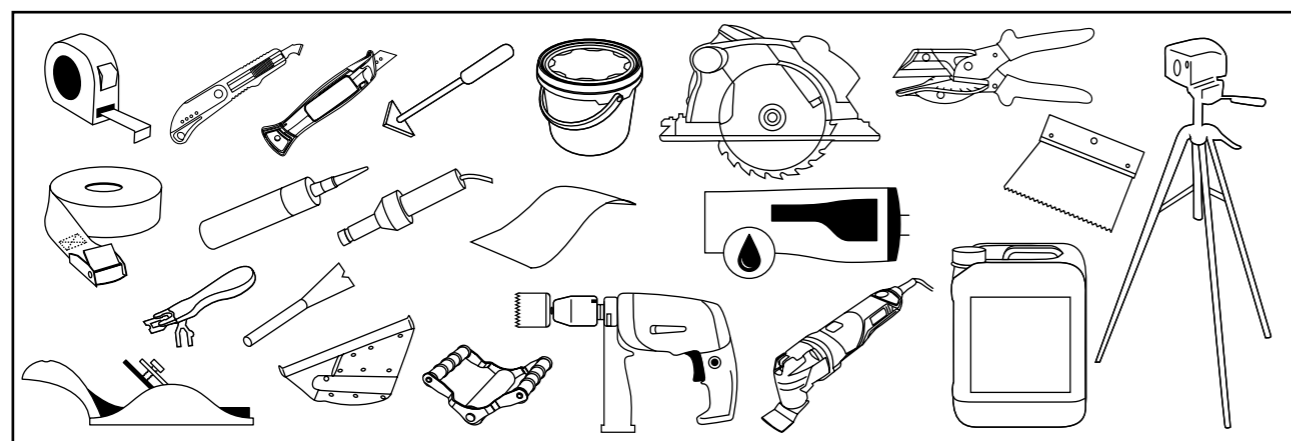

2. CONDITIONS FOR INSTALLATION

Unless otherwise specified, the procedure for installing DECOCHOC panels applies to the other PVC panels in the SPM range.

BEFORE FITTING:

- Check the humidity levels of the wall surface to be glued at several points using a humidity tester. The humidity levels of the surface **must not exceed 4%**. When using SPM MS Polymer glue, and only in this case, the possible humidity of the surface is not a constraint.
- Check that the wall surface is not greasy or loose, and that there are no large holes, otherwise they must be repaired with a suitable filler before installation (in this case, apply a coat of primer to prevent the filler from absorbing all the glue). Check that the wall is not exposed to the risk of rising damp.
- Panels must be at the same temperature as the premises in which they are to be fitted (for at least 24 hours) and stored away from bad weather to allow the panels to acclimatise before fitting. Panels must be stored flat.
- If panels are supplied in rolls, they must be stored for 48 hours according to the same conditions above.
- Any HVAC systems in the premises must be tested before panels are fitted.
- If panels will be exposed to temperature changes, expansion joints must be provided accordingly.
- Panels must be stored flat in a clean, dry area with adequate ventilation and protected from UV light.
- If installation is carried out at a temperature significantly different from 20°C (unheated premises during the winter), take account of the variations shown in the table below when fitting the panels.
- **Check with SPM whether the installation method is compatible with the fire classification report for the premises where the panels are going to be fitted.**
- **Check the characteristics of the wall meet the DTU 59.4.**

TABLE OF DIMENSIONAL VARIATIONS FOR DECOCHOC PANELS

Minimum recommended temperature: 15°C

Maximum recommended temperature: 30°C

TEMPERATURE IN °C	DIMENSIONAL VARIATIONS (in mm for each metre of length)	COMMENTS
15	- 1	Minimum temperature
20	0	Ideal temperature
25	+ 1	Admissible temperature
30	+ 2	Maximum temperature

During installation, bear in mind that the panel expansion rate is 1 mm per metre for every 5°C.

If the panels are to be fitted in a very hot or cold building, and before the HVAC system is switched on, which could cause the panels to contract or expand, we would advise you to use panels of a shorter length to spread the dimensional variations over a larger number of joints.

The SPM MS Polymer glue allows to strongly limit the SPM panels expansion by fourfold reducing of the above dimensional variations.

3. FIXING DECOCHOC PANEL

- DECOCHOC panels can be fixed using glue or adhesive, depending on the type of substrate that needs protecting. The table below shows the installation techniques to be used for the main types of wall surface found in the building industry.
- For each type of fixing, it is important to press down on the bonding surfaces with even pressure, starting in the centre of the panel and working towards the outside.

TYPE OF SUBSTRATE	FIXING PROCEDURE
PLASTER, PLASTERBOARD ⁽¹⁾	SPM Acrylic glue, SPM MS Polymer glue
BRICK, CEMENT ⁽¹⁾	SPM Acrylic glue, SPM MS Polymer glue
WOOD	SPM Acrylic glue, SPM MS Polymer glue
TILES, GLAZED TILES ⁽²⁾	SPM Acrylic glue, SPM MS Polymer glue
ROUGH SURFACES, SUCH AS GLASS FIBRE, WALLPAPER AND ROUGH-CAST PAINT ⁽³⁾	SPM Acrylic glue, SPM MS Polymer glue
PVC ^{(4) (8)}	SPM Acrylic glue, SPM MS Polymer glue, double-sided adhesive transfer tape ⁽⁷⁾
SHEET METAL ⁽⁸⁾	SPM Acrylic glue (metal protected by anti-rust paint), SPM MS Polymer glue, double-sided adhesive transfer tape ⁽⁷⁾
LAMINATES ^{(5) (8)}	SPM Acrylic glue, SPM MS Polymer glue, double-sided adhesive transfer tape ⁽⁷⁾
GLOSS PAINTED SURFACES ^{(4) (8)}	SPM Acrylic glue, SPM MS Polymer glue, double-sided adhesive transfer tape ⁽⁷⁾
GLASS, PERSPEX ⁽⁸⁾	SPM Acrylic glue, SPM MS Polymer glue, double-sided adhesive transfer tape ⁽⁷⁾

Only fixing with SPM acrylic glue or SPM MS Polymer glue, on the walls, allows to keep the Bs2d0 reaction to fire.

- (1): In case of absorbent surfaces, such as plasterboard, plaster and cement, our recommendation is to apply SPM universal primer (reference AC005SCO) to make the surface less porous and ensure a perfect finish before fitting the panels.
- (2): When fitting panels on glazed tiles, check that the surface is well degreased ; in case of very smooth glazed tiles, a light sanding is recommended. In case of harsh conditions (high-pressure washers, pooling water, etc.), and in case of acrylic glue, protect the adhesive film with a silicone joint around the panel.
- (3): For all rough surfaces, apply sufficient glue to the surface to cover all protrusions. Check that the initial covering is water-compatible in the case of acrylic glue. Wherever practicable, sand the surface to remove as many protrusions as possible (such as fleck paint). Plan to use a slightly larger quantity of glue. Check beforehand that the glass fibre (or wallpaper) is adhering properly to the wall. Otherwise, it must be completely removed.
- (4): When fitting over an existing PVC panel, check that the original panel is adhering properly to the surface and can take the extra weight. Allow for a long open time when using acrylic glue.
- (5): When using glue, you are advised to roughen up the surface to improve the glue's adherence.
- (6): Check that the paint is completely dry. With this type of smooth surface, you are advised to roughen the surface with a light abrasive.
- (7): Double-sided adhesive transfer tape is recommended only on doors. Do not use on panels subject to expansion or in damp areas.
- (8): When fitting on a non-porous surface (PVC, Perspex, sheet metal, etc.), allow for a long open time for the acrylic glue before fitting the panel or use SPM MS Polymer glue.



INSTALLING DECOCHOC

■ 3.1 INFORMATION ABOUT SPM ACRYLIC GLUE

- SPM acrylic glue is solvent-free and odourless. It complies with applicable french legislation governing **public-access buildings**.
- This glue sticks to absorbent and non-absorbent surfaces and has a high degree of tack.
- Surfaces must be dry, clean and free of all traces of glue (DTU 59-4 code of practice). A coat of primer must be applied to all porous surfaces. In case of smooth surfaces, such as painted doors, roughen with a light abrasive before applying the glue.
- The glue must be applied to all types of surface using a spreader with a notched profile (type A2).
- SPM acrylic glue has an open time of approximately 40 minutes at temperatures between 18 and 25°C, with a relative humidity level of 65%. The open time varies according to the temperature, the humidity level and the porosity of the surface. When fitting on a non-porous surface (PVC, stainless steel, laminates, etc.), allow for a long open time before fitting the panel.
- Fresh glue streaks can be removed with warm water. Dried glue can be removed using a PVC spatula.
- SPM acrylic glue can be stored for 12 months in its original packaging in a temperate room, but must be protected from frost (it is irreversibly damaged at -2°C).

■ 3.2 INFORMATION ABOUT SPM MS POLYMER GLUE

- SPM MS Polymer glue complies with applicable french legislation governing **public-access buildings**.
- This glue sticks to absorbent and non-absorbent surfaces and has a high degree of tack.
- Surfaces must be dry, clean and free of all traces of glue (DTU 59-4 code of practice). A coat of primer must be applied to all porous surfaces. In case of smooth surfaces, such as painted doors, roughen with a light abrasive before applying the glue.
- The glue must be applied to all types of surface using a spreader with a notched profile (type A2).
- SPM MS Polymer glue has a setting time (repositioning time of the panel) of approximately 40 minutes in ideal conditions of fixing between 18 and 25°C, a temperature of the surface over 15°C and a relative humidity level less than 65%. A low temperature and a low air humidity extend the working times as well as hardening and drying out times ; a high temperature and a high humidity reduce them.
- Fresh glue streaks can be removed with a rag wetted with F solvent. Dried glue can be removed using a PVC spatula.
- SPM MS Polymer glue can be stored for 12 months in its original packaging in a temperate room. Frost resistance upto - 25°C.

■ 3.3 INFORMATION ABOUT SPM UNIVERSAL PRIMER

- SPM universal primer is used to pre-treat absorbent mineral surfaces, such as cement, plasterboard, calcium sulphate, plaster and fibrous plasterboard. It ensures a perfect finish before applying the glue. Primer creates an even wall surface, improves adhesion of the glue and allows panels to be bonded in place more securely, while reducing the amount of glue used.
- The primer is solvent-free and produces very low VOC emissions (Class A+).
- Pour the primer into a clean bucket. Use a nylon roller to apply a thin, even coat across the entire surface. Average consumption: 100 to 150 g/m². Allow to dry. The film should be almost tack-free.

Drying time:

- Cement surfaces: approximately 45 min
- Calcium sulphate surfaces: approximately 3 hours
- Plaster-based surface: approximately 3 hours
- Fibrous plasterboard: approximately 3 hours
- Clean tools with water immediately after use.
- SPM primer can be stored for 12 months in its original packaging in a temperate room, but must be protected from frost (it is irreversibly damaged at -2°C).

■ 3.4 DAMP ENVIRONMENTS DURING INSTALLATION

In especially damp places where the relative humidity exceeds 90%, the SPM MS Polymer glue is particularly suited.



In cool, damp environments, using a fan heater can reduce the open time for the acrylic glue.

INSTALLING DECOCHOC

■ 3.5 DAMP ENVIRONMENTS AFTER INSTALLATION

In damp environments where the relative humidity is important after installation, allow for a peripheral silicone joint so that damp not alters the acrylic glue.



When using the SPM MS Polymer glue, this peripheral joint is not required.

■ 3.6 ENVIRONMENTS AT LOW TEMPERATURE

DECOCHOC panels can also be installed in positive cold rooms (temperature from 5°C to 10°C) if using the SPM MS Polymer glue. Before installation take the dimensional variations according to the temperature into account (see page 13). Handle panels with care as the cold makes the panels brittle.

4. INSTALLATION PROCEDURE

■ 4.1 CUTTING AND ADJUSTING DECOCHOC PANELS

- Measure each section of wall and then cut the DECOCHOC panels to the required heights and lengths (see Fig. 1).
- Even though panels feature a multi-directional grain, you are advised to follow the fitting direction shown by the arrows on the back of the panels in case of specific layout designs (wall washer lighting, large surface areas, full height installations, etc.).
- Use numbers to mark the location of the panels on the wall sections (see Fig. 1).
- To cut panels, use a utility knife or hooked knife. If cutting several panels, use a circular saw with a guide rail (see Fig. 2).
- Place the panels against their respective wall sections and check for alignment against mouldings, skirting and floors.
- For squareness, place the panel horizontally with the aid of a laser level and then adjust the panel with a plane, utility knife or hooked knife.
- Once the panels are squared, place each panel against its respective wall section and use a pencil to mark out the area to be glued on the wall (5 mm inside the edges of the panel).

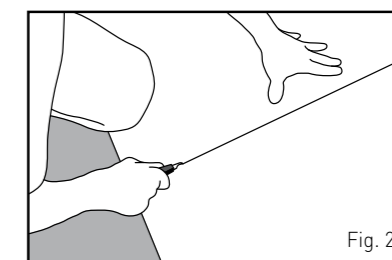
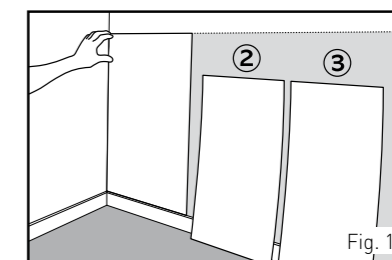

- Panels can be chamfered at the same time by cutting with a circular saw tilted on its guide to produce a bevel cut.
- Cutouts for wall switches and mains sockets can be made using a hole saw.

■ 4.2 INSTALLATION METHOD

Panels must be fitted one after the other. The first panel must be adjusted and fixed to the wall before the second panel can be properly aligned with the first (especially when jointing). In the case of installation of full panels, as they are directly issued from extrusion, take a 0.2 % squareness tolerance into account because of that production process.

Panels can be jointed:

- With an SPM thermowelded joint in a matching colour
- With an SPM silicone joint in a matching colour
- By laying edge-to-edge the panels (only where temperature conditions are perfectly stable)
- With finishing profiles

Handrail brackets can only be fixed onto DECOCHOC panels where temperature conditions are perfectly stable (otherwise the brackets could prevent the panels from expanding, causing them to come away from the wall).

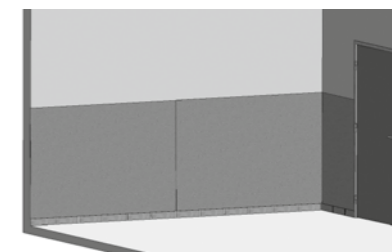
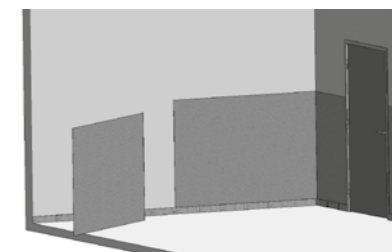



INSTALLING DECOCHOC

■ 4.3 INSTALLATION WITH SPM ACRYLIC GLUE AND FIXING THE DECOCHOC PANELS

- The glue is applied with a stainless steel spreader with a notched profile (type A2) in order to use a quantity of 250 to 320 g/m².
- Spread the glue over the entire wall surface that was marked out earlier. Applying it to the wall instead of the panel avoids getting dust on the adhesive and reduces the open time (see Fig. 1).
- Once the surface has been completely covered, allow for an open time of 25 to 40 minutes* before fixing the panel.

* The open time depends on the type of surface, the relative humidity level, the temperature and the bonding method.

- Check the glue's open time by placing a fingertip against different parts of the glued surface. If filaments appear when the finger is withdrawn, the required open time has been achieved. When the open time has been reached, the glue will retain its adhesive power for 15 to 40 minutes* (see Fig. 2).

* The open time depends on the type of surface, the relative humidity level, the temperature and the bonding method.

- It is important to clean all of the panel's smooth surface (glue side) using a tack rag before each gluing session (see Fig. 3).
- Set the DECOCHOC panel in place while respecting the predefined wall clearances on each side (see Fig. 4).
- Using a roller, press down on the entire surface of the panel, starting in the centre and working towards the outside. Then press down along the edges (see Fig. 5).
- Clean off any excess glue with a rag and hot water.
- If necessary, finish off the top of the panel with sandpaper or a utility knife to remove the sharp edge and leave a slight chamfer.
- If cleaning with hydrogen peroxide (H₂O₂), a seal must be created around the outside of the panel.

■ 4.4 INSTALLATION WITH SPM MS POLYMER GLUE

- Fixing of DECOCHOC panels with SPM MS Polymer glue is recommended for quick and ideal installation in premises especially damp when installing.
- SPM MS Polymer glue is applied in the same way as the acrylic glue ; only the following points are different:
 - No open time required.
 - Once the surface has been completely covered, panels can be fixed immediately upto the setting time of the glue that is about 40 minutes.
 - Clean off any excess glue with a rag and F solvent.

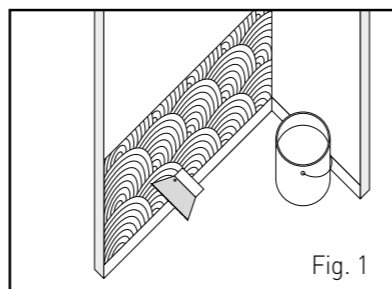

Fig. 1

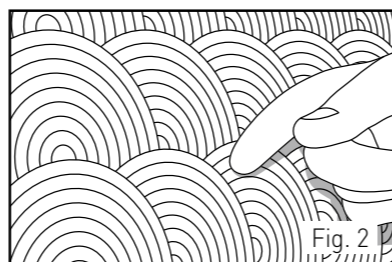

Fig. 2

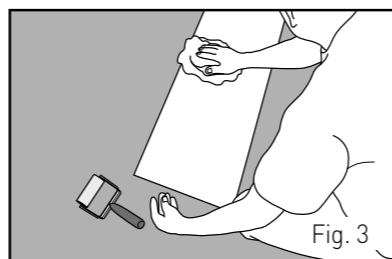

Fig. 3

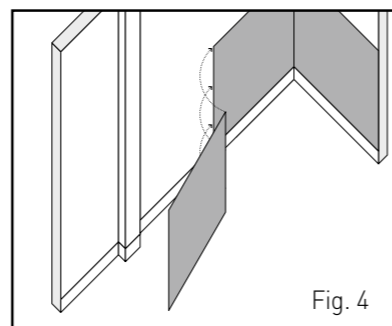

Fig. 4

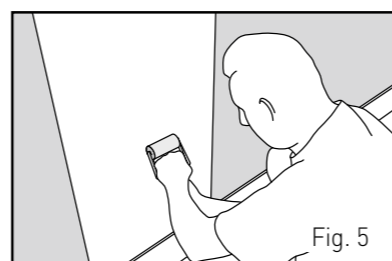
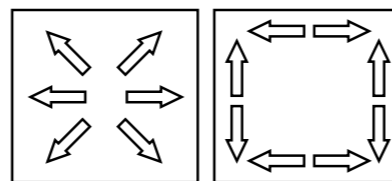

Fig. 5



INSTALLING DECOCHOC

■ 4.5 LAYING THERMOWELDED JOINTS

Thermowelded joints are used to provide an effective tightness when assembling two DECOCHOC panels together, or any DECOCHOC panel against PVC coving.

⚠ Wait 24 hours between gluing the panels and creating the thermowelded joints.

- Check that there is a 2-mm gap between the panels.
- Use a chamfering tool to create a clean chamfer of approximately 1 mm between the two panels.
- Cut a length of welding rod and add 10 cm to the working length.
- Check that the melt-gun nozzle is clean.
- Adjust the gun temperature to approximately 450°C (setting 4.5 for the welding gun supplied in the SPM set). Let the gun warm up for five minutes before starting work.
- Feed the welding rod into the nozzle and then begin laying the joint.
- When starting the joint, hold the rod in place with a finger for the first five centimetres.
- Slowly work downwards along the length of the joint, ensuring good adhesion between the joint and panel without burning the panel. Good adhesion can be seen when two small beads appear on each side of the joint. Work down the joint at a constant speed.
- At the end of the joint, keep pressure on the end of the joint for a few seconds, so that the gun can be cleanly removed.
- Set the gun to the 0 setting until it has cooled down completely and then switch the gun off.
- Clean the nozzle using a brass brush.
- Cut back any excess rod above and below the joint using a knife.
- Pre-trim the joint with the Mozart trimming knife set to its maximum height.
- To ensure an effective cross-linked joint, let the weld cool until the joint is at the same temperature as the panel (approximately 10 minutes).
- Trim the joint again with the Mozart trimming knife set to its minimum height. Joints must be trimmed in a single movement.

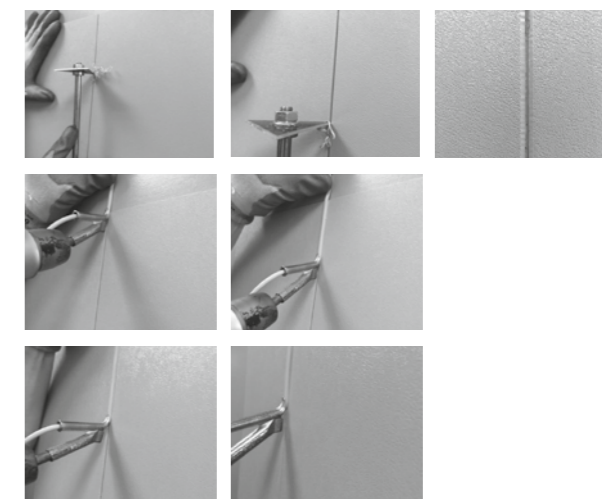

Good weld = Pressure + Speed + Heat

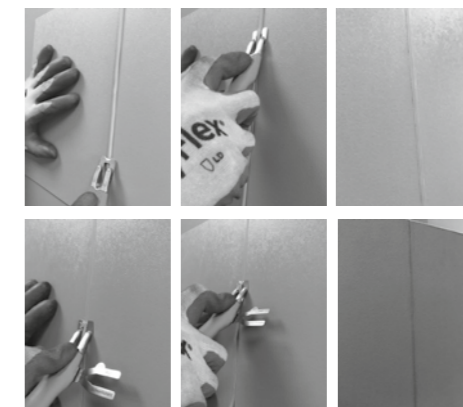
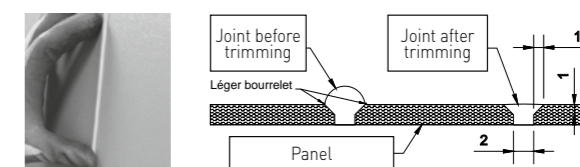

■ 4.6 LAYING SILICONE JOINTS

Silicone joints are used to provide a good tightness between DECOCHOC panels and mouldings, skirting or between panels in corners.

Two methods may be used:

Either:

- Check that there is a 2-mm gap between the panels and the moulding.
- Apply a strip of masking tape on each side of the joint.
- Use a caulking gun to apply a bead of silicone along the length of the joint.
- Spread the silicone joint using a fingertip.
- Remove the adhesive protection tapes.

Or:

- Check that there is a 2-mm gap between the panels and the moulding
- Use a caulking gun to apply a bead of silicone along the length of the joint
- Spray soapy water on the bead
- Just after, remove the excess of silicone with a scraper



INSTALLING DECOCHOC

4.7 INSTALLING FIN'COLOR FINISHING AND JOINTING PROFILES

FIN'COLOR is a PVC finishing and jointing profile. It is used in the following cases:

- Horizontal finishing on top of DECOCHOC panels. (see Fig. 1 and 2).
- Horizontal finishing for joints between DECOCHOC panels / coving.

Product dimensions: profiles in lengths of 3,000 mm.

4.7.1 FIXING THE PRODUCT

FIN'COLOR profiles are fixed to the wall using acrylic glue or adhesive sealant.

4.7.2 CUTTING THE PRODUCT

FIN'COLOR profiles are flexible and can be easily cut with a utility knife. For a clean finish, you are advised to use a mitre shear cutter.

4.7.3 HORIZONTAL FITTING

Horizontal finishing on top of panels - J-shaped profile (see Fig. 2).

- Cut the FIN'COLOR profile to the same length as the panel.
- Place the FIN'COLOR profile on top of the panel.
- Apply the panel and the FIN'COLOR profile at the same time to the wall that has been coated with adhesive.
- Smooth over the panel/FIN'COLOR assembly.

4.7.4 VERTICAL FITTING

Vertical fitting for joints between panels - H-shaped profile (see Fig. 3).

- Cut the FIN'COLOR profile to the same height as the panel.
- Glue the FIN'COLOR mounting base where the panels will be jointed.
- Glue the panels to the mounting base as shown in the diagram.
- Clip the FIN'COLOR cover onto the mounting base.
- Smooth over the panel/FIN'COLOR assembly.
- Finish the top with a silicone joint.

4.7.5 COMBINED HORIZONTAL AND VERTICAL FITTING

- Measure the lengths and heights to be cut.
- Cut the H-profile mounting base (panel height - 11 mm).
- Glue the H-profile mounting base to the wall where the panels will be jointed.
- Cut the J-shaped profile to the required length.
- Place the J-shaped profile on top of the panels (leave a 3-mm gap between the panels).
- Glue the panels to the H-profile mounting base (see Fig. 3).
- Measure, cut and clip the H-profile cover onto the mounting base.
- Smooth over the panel/Fin'Color assembly.

4.8 INSTALLING FIN'ALU FINISHING AND JOINTING PROFILES

FIN'ALU is an anodised aluminium finishing and jointing profile. It is used in the following cases:

- Horizontal finishing on top of DECOCHOC panels.
- Vertical finishing for joints between DECOCHOC panels.
- Product dimensions: profiles in lengths of 3,000 mm.

The H-shaped profile comprises two parts: a cover to snap-fix onto a mounting base.

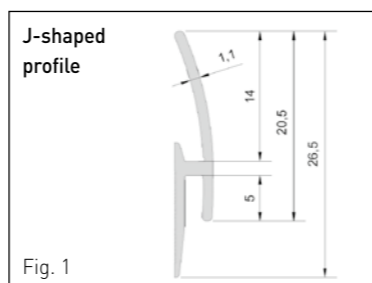

Fig. 1

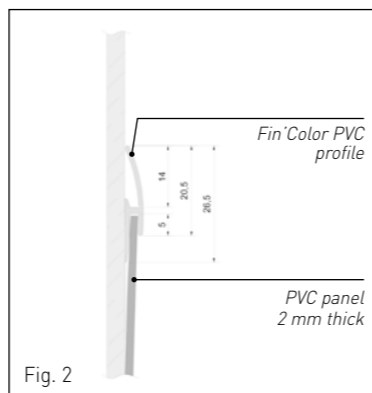

Fig. 2

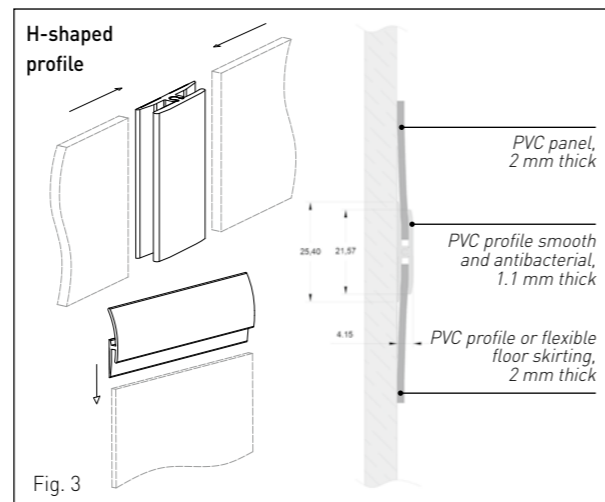
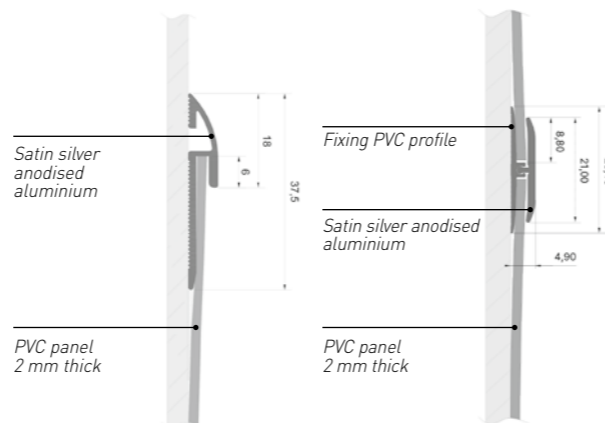

Fig. 3

J-shaped profile

H-shaped profile



INSTALLING DECOCHOC

4.8.1 FIXING THE PRODUCT

FIN'ALU profiles are fixed to the wall using SPM acrylic glue or SPM MS Polymer glue.

4.8.2 HORIZONTAL FITTING

Horizontal fitting on top of panels - J-shaped profile

- Cut the FIN'ALU profile to the same length as the panel.
- Place the FIN'ALU profile on top of the panel.
- Apply the panel and the FIN'ALU profile at the same time to the wall that has been coated with adhesive.
- Smooth over the panel/FIN'ALU assembly.

4.8.3 COMBINED HORIZONTAL AND VERTICAL FITTING

- Measure the total length of the wall to be covered.
- Apply the glue to the wall.
- Measure the height of the panel and subtract 25 mm to obtain the length of the FIN'ALU profile in the vertical jointing position (H-shaped profile).
- Position the H-profile mounting base along the side of the panel and leave a 5-mm gap between the base and the edge of the panel, as well as a 25-mm gap from the top edge of the panel (see Fig. 1).
- Apply the panel and the FIN'ALU profile at the same time to the wall that has been coated with glue (see Fig. 2).
- Position and glue the second panel on the other side of the mounting base in the same way as the first panel (see Fig. 2).
- Cut the horizontal FIN'ALU profile (J-shaped profile) to the dimensions of the wall and place the FIN'ALU profile along the top of the panels (see Fig. 2).
- Smooth out the FIN'ALU/panel assembly.
- Then measure the vertical distance between the bottom of the panel and the edge of the J-shaped profile.
- Cut the aluminium H-profile to this length.
- Snap-fix the aluminium H-profile onto the PVC fixing profile (See Fig. 3).
- Smooth out the assembly.

4.9 INSTALLING ON ROUND PILLARS

Protection can be fitted to round pillars with pre-shaped DECOCHOC panels that have been curved by hot-forming to fit the dimensions of the pillar. Each pillar is protected by two thermoformed panels (in two halves).

DECOCHOC panels need to be thermoformed for pillar diameters up to 750 mm. Over 750 mm, panels are sufficiently flexible to be fitted to curved surfaces.

Thermoformed DECOCHOC panels are oversized by 10 mm in both width and height to allow for adjustment when fitting.

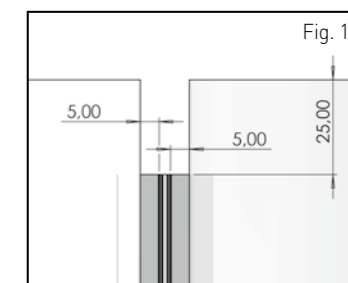
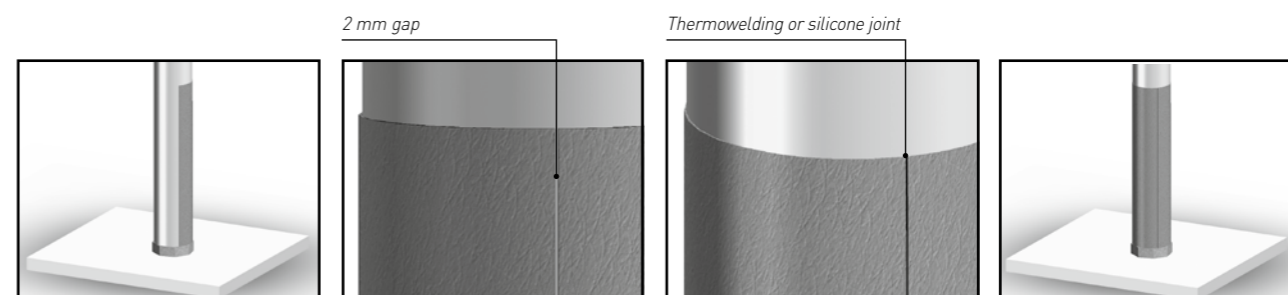

Step 1: position the base plate in relation to the edge of the DECOCHOC panel according to the above dimensions.

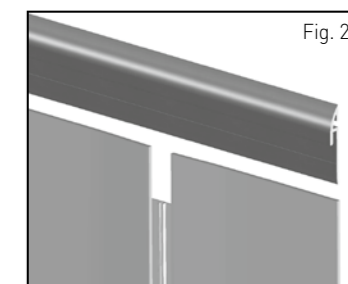

Step 2: position the horizontal finishing profile.

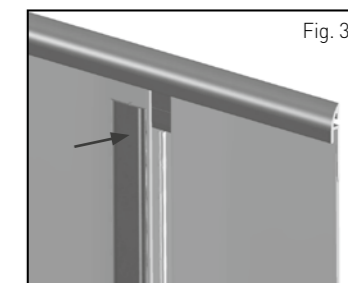

Step 3: fit the vertical jointing cover.



INSTALLING DECOCHOC

- Fit the first thermoformed panel using the specific procedure for fitting DECOCHOC panels.
- Mark out the areas to be glued and then apply the glue to the pillar.
- Then fit the second panel while leaving a 2-mm gap between the two panels on each side.
- Once the two panels have been fitted, seal the panels with a thermowelded or silicone joint on either side of the pillar.
- In case of difficulty in fitting the two shells around the edges, especially where the pillar features an irregular rounded shape, we recommend gluing them down, covering the joints with a timber batten and then strapping the two half panels at several points for the entire drying time of the glue (at least 24 hours).

■ 4.10 INSTALLING DECOCHOC PANELS WITH BENDS FOR ANGLES

If fitting DECOCHOC panels in operating theatres or cleanrooms, it is essential to create a good tightness between wall panels and also with the PVC flooring. To achieve an effective tightness, we offer bends in internal and external angles that fit to DECOCHOC panels with a thermowelded joint to ensure a complete tightness within the room and help make cleaning much easier.

- When fitting DECOCHOC panels with bends for angles, fit all the internal and external angles in the room before fitting the flat panels.
- Fit the angle bends and flat panels using the appropriate fitting procedure.
- Leave a 2-mm gap between each panel for laying the thermowelded joint.
- Lastly, lay the thermowelded joints using the specific procedure (Section 4.5).

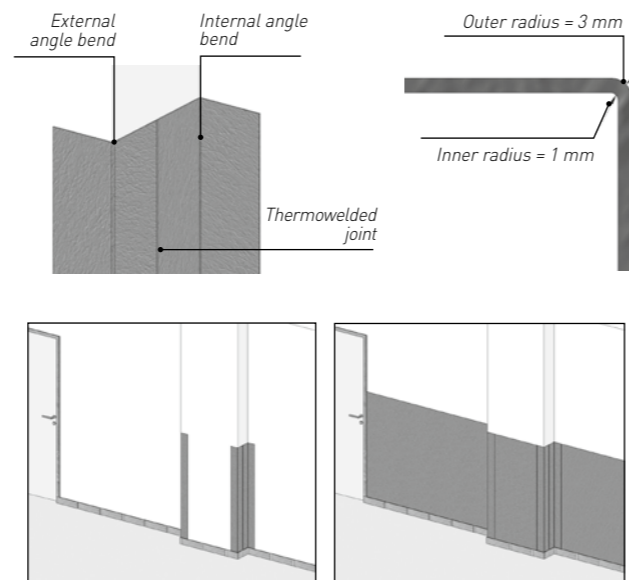

■ 4.11 FITTING DECOCHOC PANELS TO DOORS

Protecting door faces

- Remove the door from the doorway and place on trestles.
- Remove the handle and the lock fixing plate.
- Use a drill with a hole saw to make cutouts in the panel for the handle and lock.
- Then glue down the panel(s) to the door faces.
- Replace the handle and the lock fixing plate.

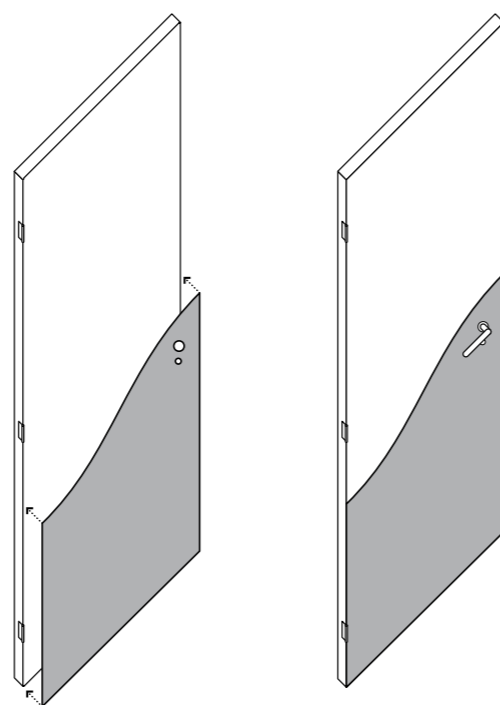
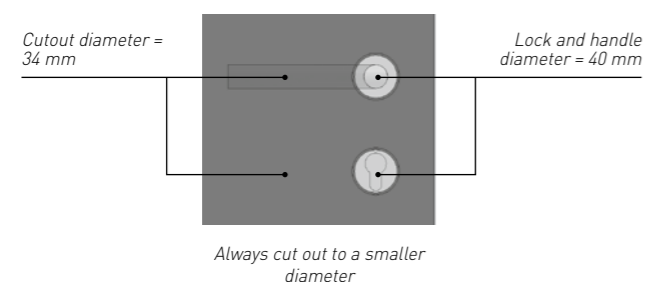

INSTALLING DECOCHOC

Protecting door faces and edges

- Remove the door from the doorway and place on trestles.
- Remove the handle and the lock fixing plate.
- Use a drill with a hole saw to make cutouts in the panel for the handle and lock.
- Remove any door hinges that might obstruct when trimming the door.
- Create a rebate for the panels by using a circular saw to trim 2 mm off the left and right edges.
- Make cutouts in the panels for the hinges.
- Glue the U-shaped panel to one side of the door.
- Then glue the other U-shaped panel to the other side while leaving a 2-mm gap between the two panels (plane or cut the panels to size if necessary).
- Replace the hinges, handle and lock fixing plate.
- Finally, lay a thermowelded joint along both edges of the door.

Protecting complete doors:

- Remove the door from the doorway and place on trestles.
- Remove the handle and the lock fixing plate.
- Use a drill with a hole saw to make cutouts in the panel for the handle and lock.
- Remove any door hinges that might obstruct when trimming the door.
- Create a rebate for the panels by using a circular saw to trim 2 mm off the left, right and bottom edges of the door.
- Make cutouts in the panels for the hinges.
- First glue the U-shaped panel protecting the bottom of the door.
- Glue the U-shaped panel to one side of the door.
- Then glue the U-shaped panels to the door faces and edges while leaving a 2-mm gap between the panels (plane or cut the panels to size if necessary). Part of the panels will be glued on top of the first panel protecting the bottom of the door.
- Replace the hinges, handle and lock fixing plate.
- Lay a thermowelded joint along both edges of the door.
- Finally, create a silicone joint around the bottom of the door.

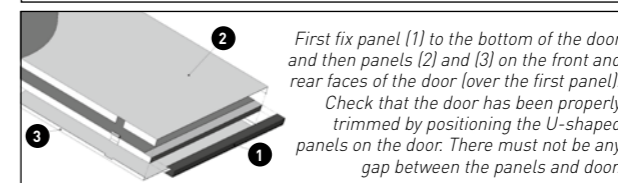
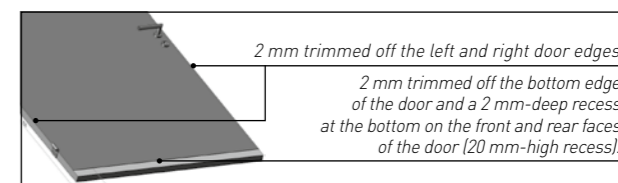
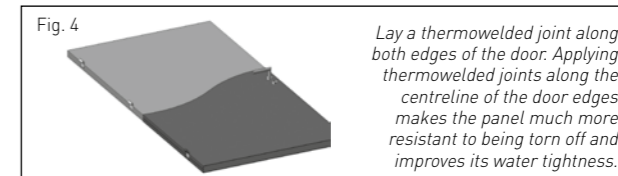
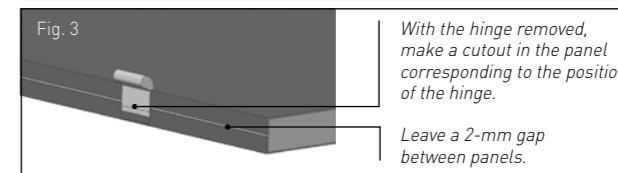
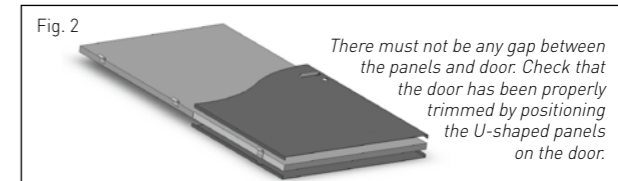
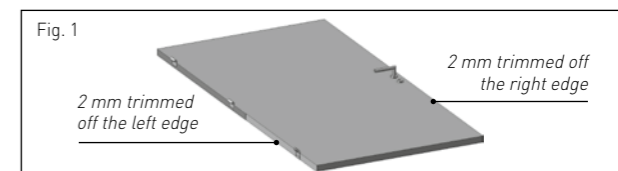

With silicone joints on door angles

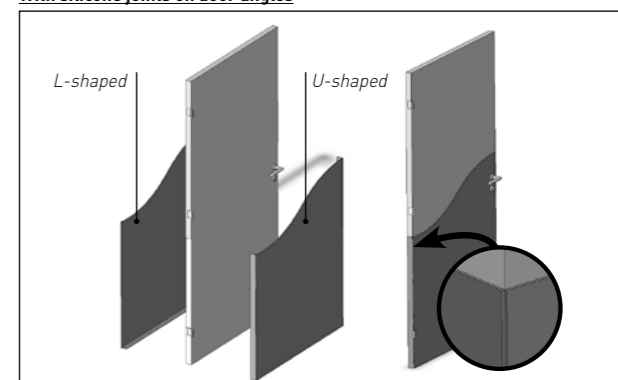

With a thermowelded joint along the door edges

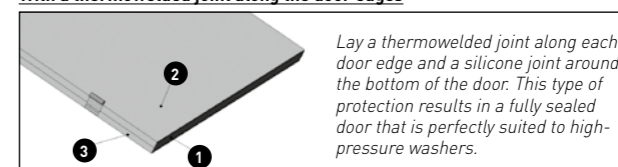



INSTALLING DECOCHOC

Cost-effective solutions

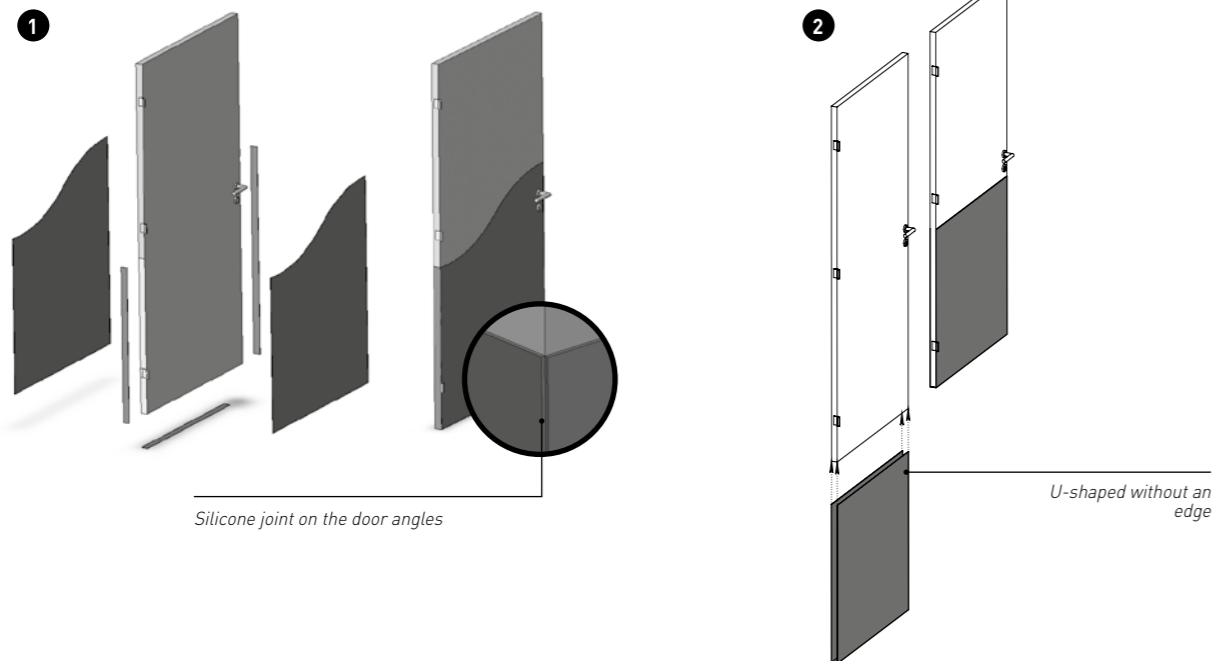

4.12 FITTING PANELS TO DOOR FRAMES

Protection can be fitted to door frames with DECOCHOC U and L-shaped panels.



Fit the panels with adhesive sealant and lay a silicone joint along the corner of the door frame.

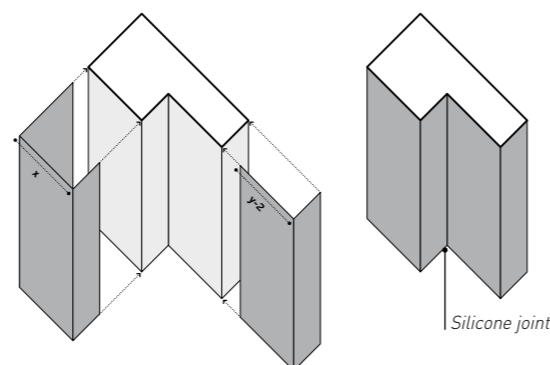

Protection can also be fitted to door frames with a single thermoformed DECOCHOC panel that has been made to measure for the door frame.

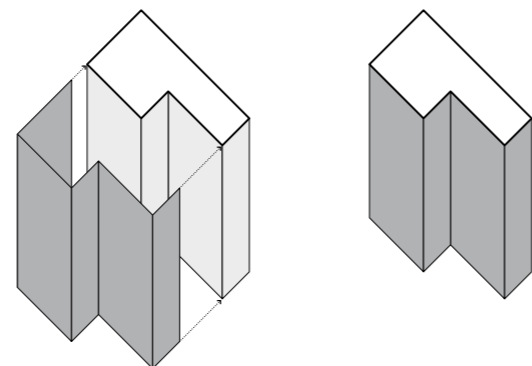

INSTALLING DECOCHOC

4.13 INSTALLING DECOPRINT PANELS

- Same installation procedure as DECOCHOC panels.
- Lay the panels edge-to-edge for a more effective finish (only where temperature conditions are perfectly stable).
- Create a watertight junction with transparent silicone.

5. DECOCHOC PANEL MAINTENANCE

DECOCHOC panels have been tested for their resistance to the main types of cleaning materials, disinfectants and antiseptic products commonly used by public buildings and healthcare facilities.

The products below have been tested and proved to cause no damage to DECOCHOC panels:

Detergents:	Detergent disinfectants:	Descalers:	Paint strippers:	Degreaser disinfectants:	Other:
• SURFANIOS	• DS5001	• TASKI CALCACID	• TASKI radical	• DDM	• 70° surgical alcohol
• DETERGANIOS	• DIVOSAN S4		• SUMA D9.7		
• UNIT PLUS					

• Products **MUST NOT BE CLEANED** with a scouring pad, such as a Scotch-Brite pad.

The following products are recommended for cleaning DECOCHOC panels:

- Ammonia
- Isopropyl alcohol
- Ethanol
- Essence F cleaner

It is essential to use solvents that do not leave any greasy or dry residue. In all cases, test the product on a scrap piece of panel. Reactions will differ depending on the colour of the panels and the solvents used.

DO NOT USE:

- White spirit
- Acetone
- Petrol
- Paint thinners

6. RESTRICTIONS

HEAT SOURCES

- The panels in the Decochoc range must not be exposed to dry heat sources (hobs, stoves, countertop ovens, mini ovens, etc.) **over 60°C**. If applicable, they must be **protected with a Plac'Inox protection plate** to shield the panels against thermal stresses. Plac'Inox plates must not be exposed to a **surface temperature in excess of 90°C**.
- The panels in the Decotrend/Decowood range must not be exposed to dry heat sources (hobs, stoves, countertop ovens, mini ovens, etc.) **over 50°C**. If applicable, they must be **protected with a Plac'Inox protection plate** to shield the panels against thermal stresses. Plac'Inox plates must not be exposed to a **surface temperature in excess of 90°C**.
- If the SPM panel is exposed to a heat source of **100°C** at a distance of less than 260 mm, it must be protected with a 600 mm-high Plac'Inox plate; the width will depend on the layout of the area requiring protection.

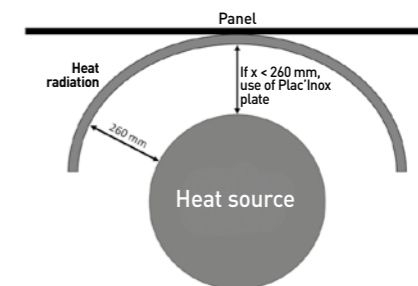

POWER WASHING: the water pressure must be **limited to no more than 3 bar on the welded joints and the temperature must not exceed 60°C**.

THE DIFFERENT SOLUTIONS must NOT be cleaned with a **scouring pad**, such as a Scotch-Brite pad.

WHEN USED TO CREATE A PROTECTIVE SURFACE ON A WORKTOP, table, workbench, bar, and so on, **pooling water on the panel** may lead to discolouration in the form of a ring or shadow on the affected areas.

INSTALLING CORNER PROTECTORS ON AN ALUMINIUM CORE

1. TOOLS REQUIRED	24
2. CORNER PROTECTORS ON ALUMINIUM CORE: CORNEA, CORNEAFLEX AND COMBO'CORNER	25/27
2.1 Installation procedure for CORNEA and COMBO'CORNER corner protectors	25
2.2 Installation procedure for CORNEAFLEX corner protectors	27
3. ADHESIVE CORNER PROTECTORS: PROFILA 30/50, PROTECTA 2, PROFIL'INOX 30/50, LINEA'FLEX	28
3.1 Installation procedure for corner protectors: PROFILA 30/50, PROTECTA 2 and PROFIL'INOX 30/50	28
3.2 Installation procedure for LINEA'FLEX corner protectors.....	28
4. ELASTO'FLEX CORNER PROTECTORS	30
4.1 Installation procedure for ELASTO'FLEX corner protectors	30
5. INDIVIDUAL PROTECTION: SAFY'CORNER AND SAFY'DOOR	30/31
5.1 Installation procedure for SAFY'CORNER	30
5.2 Installation procedure for SAFY'DOOR	31
6. MAINTENANCE	31

2. CORNER PROTECTORS ON ALUMINIUM CORE: CORNEA, CORNEAFLEX AND COMBO'CORNER

- SPM CORNEA, CORNEAFLEX and COMBO'CORNER corner protectors consist of a PVC profile mounted on an aluminium core.
- The product is finished with endcaps at the top and bottom of the protector.
- These protectors must be screwed to the wall.

The table below shows the fixing techniques to be used for the main types of wall surface found in the building industry.

TYPE OF WALL	FIXING PROCEDURE
WALLS WITH WOODEN STUDS	Woodscrews, 5 x 40 mm
METALLIC STRUCTURES	Self-tapping screws, 5 x 40 mm
PLASTERBOARD (SINGLE SKIN), HOLLOW BRICK, HOLLOW BREEZE BLOCK	Metal expansion plugs, 5 x 50 mm
PLASTERBOARD (DOUBLE SKIN)	Metal expansion plugs, 5 x 50 mm
CONCRETE WALLS	FISCHER-type plugs, 6 mm diameter for 5 x 40 mm screws
SOLID BRICK AND OLD WALLS	FISCHER-type plugs, 8 mm diameter for 5 x 40 mm screws
HOLLOW PLASTER TILES, CELLULAR CONCRETE	FISCHER-type plugs, 8 mm diameter for 5 x 40 mm screws

2.1 INSTALLATION PROCEDURE FOR CORNEA AND COMBO'CORNER CORNER PROTECTORS

CORNEA



Technical drawing
CORNEA

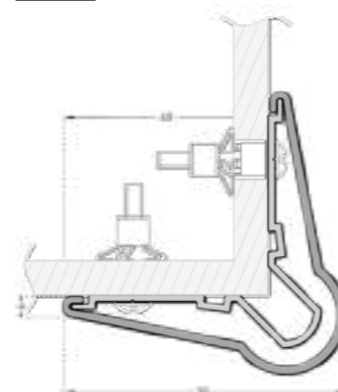

COMBO'CORNER

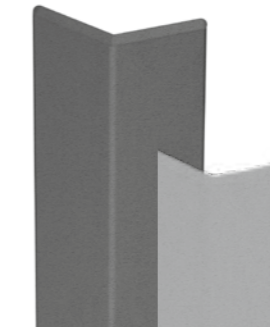

Technical drawing
COMBO'CORNER 50 and 75

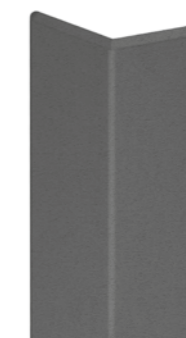
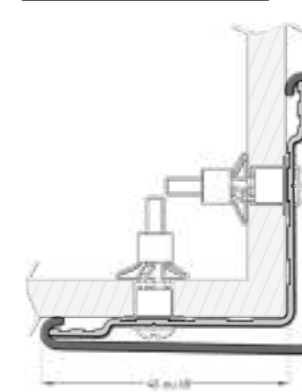

Technical drawing
COMBO'CORNER 75-135°

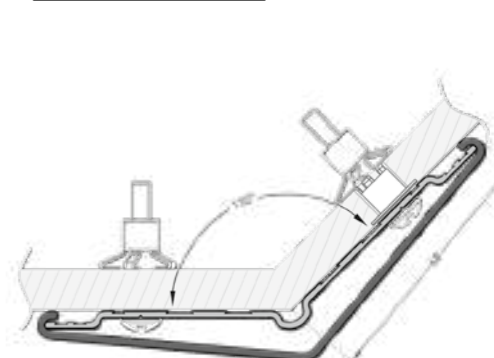

1. TOOLS REQUIRED

- Mitre saw with carbide blade for aluminium and PVC
E.g. FESTOOL KS 88E saw – Blade reference TF52
- Measuring tape
Reference: ROMUS 93290 or 93283
- Level and straight edge
- Electric drill and screwdriver
- Mallet
Reference: ROMUS 94959
- Laser

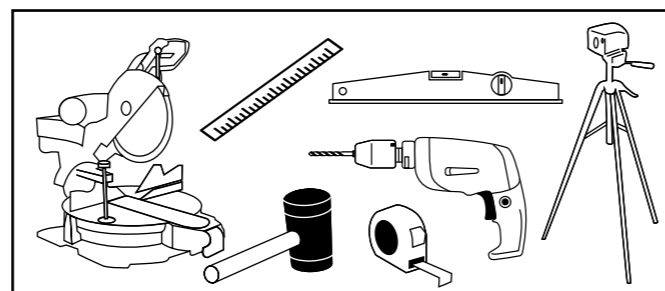

INSTALLING CORNER PROTECTORS ON ALUMINIUM CORE

- Calculate the length of the aluminium core to be cut while subtracting the dimensions of the endcaps (top and bottom) from the overall length (see Fig. 1).
- Cut the aluminium core using a mitre saw or hacksaw (see Fig. 2).
- Drill two 5 mm holes through the aluminium core at each end.
- Drill the holes at a distance of 20 mm from the edge of the core.
- Drill holes in the aluminium core along the grooves and stagger the holes for the fixing screws (20 cm between each hole) (see Fig. 3).
- Place the endcaps against the wall with the aluminium core.
- Mark the endcap and aluminium core screw holes using a pencil.
- Drill the wall, fit the plugs and screw to the wall, starting with the lower endcap, the aluminium core and then the upper endcap (see Fig. 4).
- Cut the PVC profile. You are advised to use a template beneath the profile to ensure a straight cut and avoid deforming the profile.
- Finally, fit the PVC profile by positioning one side on the aluminium core and the edges of the endcaps. Then clip the other side of the PVC profile by tapping it home (see Fig. 5).
- Remove the protective film.

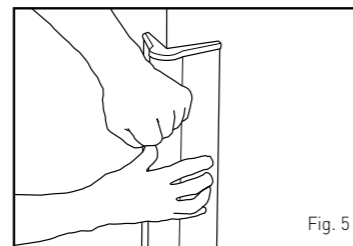
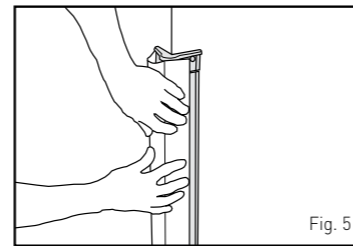
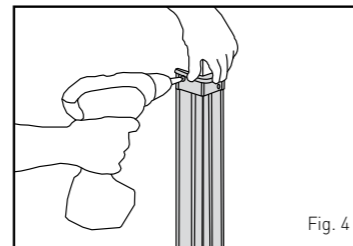
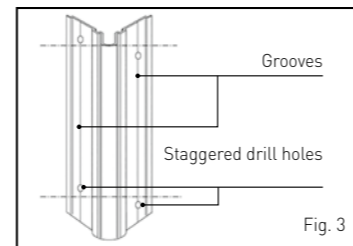
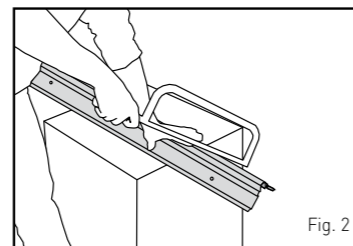
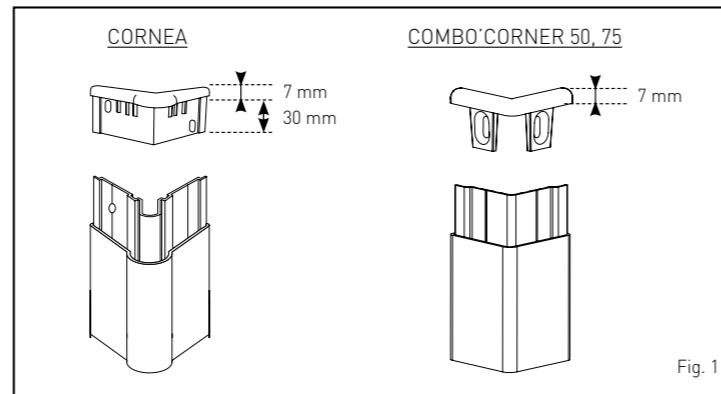

INSTALLING CORNER PROTECTORS ON ALUMINIUM CORE

2.2 INSTALLATION PROCEDURE FOR CORNEAFLEX CORNER PROTECTORS

CORNEAFLEX



Installing on aluminium core (135° angle)

- Calculate the length of the aluminium core to be cut while subtracting the dimensions of the endcaps (top and bottom) from the overall length.
- Cut the aluminium core using a mitre saw or hacksaw.
- Place the endcaps against the wall with the aluminium core.
- Mark the endcap and aluminium core screw holes using a pencil.
- Drill the wall, fit the plugs and screw to the wall, starting with the lower endcap, the aluminium core and then the upper endcap.
- Cut the PVC profile. You are advised to use a template beneath the profile to ensure a straight cut and avoid deforming the profile.
- Align the PVC profile with the endcap and insert the first wing of the PVC profile onto the aluminium core ① and then clip onto the first snap attachment ②. Insert the second wing of the PVC profile onto the aluminium core ③ and then clip onto the second snap attachment ④.
- Remove the protective film.

Installing on double aluminium cores (variable angle 80° to 135°) - floor-to-ceiling

- Calculate the length of the corner that needs protecting.
- Drill two 5 mm holes through the aluminium core at each end.
- Drill the holes at a distance of 20 mm from the edge of the core.
- Drill holes in the aluminium core along the grooves and stagger the holes for the fixing screws (20 cm between each hole)
- Place one of the cores against the wall and mark the fixing holes.
- Drill, plug and screw the core to the wall.
- Then clip the PVC profile to both cores and position the whole assembly against the wall.
- Mark out the position of the second core.
- Remove the assembly. Replace the core against the marks and mark out the fixing holes.
- Drill, plug and screw the second core to the wall.
- Insert the first wing of the PVC profile onto the aluminium core ① and then clip onto the first snap attachment ②. Insert the second wing of the PVC profile onto the aluminium core ③ and then clip onto the second snap attachment ④.
- Remove the protective film.

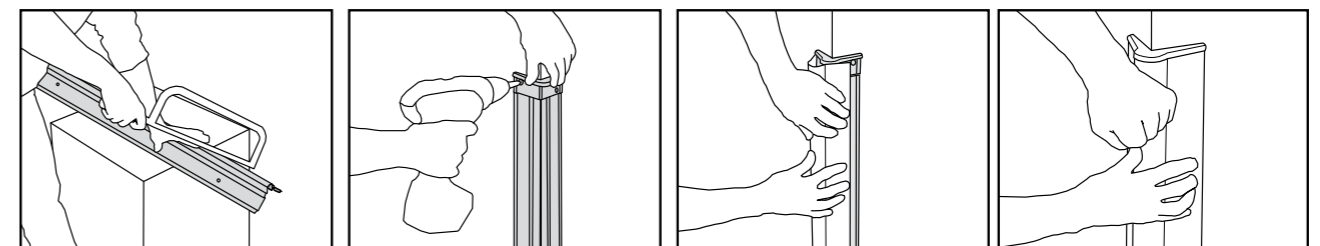

135° ENDCAP

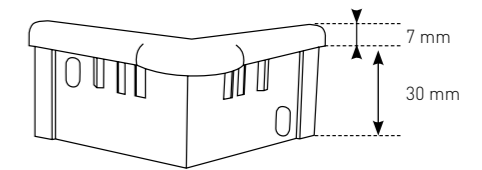

Technical drawing
135° angle CORNEAFLEX

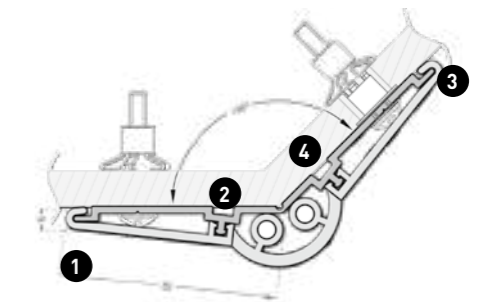

Technical drawing
Variable-angle CORNEAFLEX

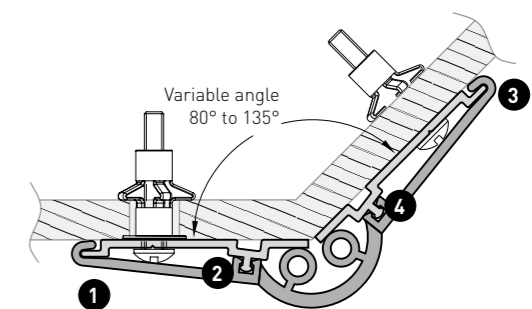

INSTALLING ADHESIVE CORNER PROTECTORS

3. ADHESIVE CORNER PROTECTORS: PROFILA 30/50, PROTECTA 2, PROFIL'INOX 30/50 AND LINEA'FLEX

- SPM PROFILA 30/50, PROTECTA 2 and LINEA'FLEX corner protectors consist of a 2 mm thick PVC profile.
- SPM PROFIL'INOX 30/50 corner protectors consist of a 1 mm thick stainless steel profile.
- These protections are fixed directly to the wall using SPM adhesive sealant.
- Adhesive foam tapes are laid along the edges to temporarily hold the protection in place while the sealant dries (tack time). The adhesive foam tapes are in no way designed to provide permanent support.

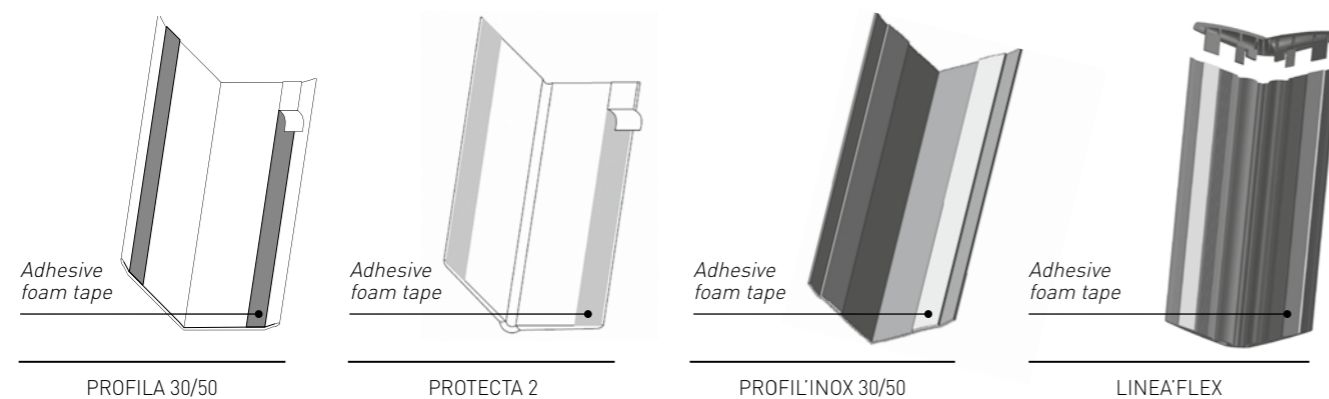

3.1 INSTALLATION PROCEDURE FOR CORNER PROTECTORS: PROFILA 30/50, PROTECTA 2, AND PROFIL'INOX 30/50

- Apply the SPM adhesive sealant to the surface of the PVC profile as shown in the diagram below:

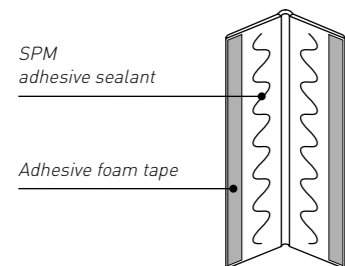

- Remove the protective film from the adhesive foam tapes.
- Place the protection against the wall.
- Press down hard (with a roller) all across the outer surface of the PVC profile.
- Clean off any excess sealant with a rag and hot water.
- Remove the protective film.

3.2 INSTALLATION PROCEDURE FOR LINEA'FLEX CORNER PROTECTORS

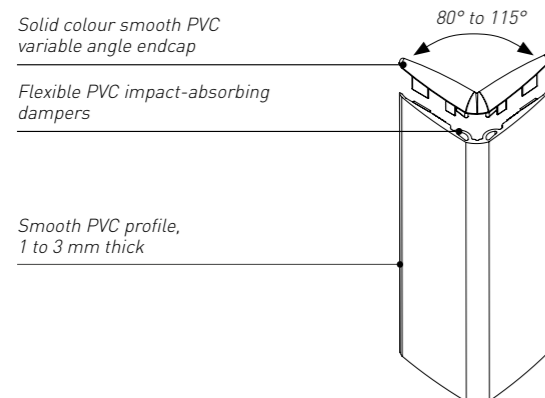

INSTALLING ADHESIVE CORNER PROTECTORS

Cutting the profile

- The corner protector profile can be cut with a mitre saw. Our recommendation is to use a fine-toothed carbide blade for aluminium and PVC.
- To ensure a straight cut and avoid splintering the surface, you are advised to use a template.

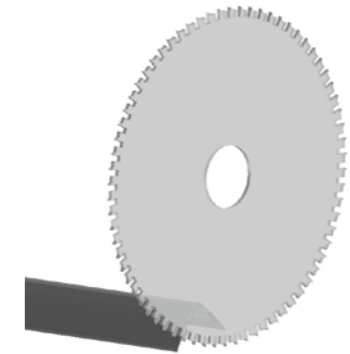

Assembling the endcap

- Insert the two centre tabs of the endcap into the corner protector's impact-absorbing dampers.
- Push the endcap into the dampers and make sure that it is securely in place.
- Carefully peel away the protective film from the adhesive tape and fix the two outer tabs of the endcap onto the adhesive.

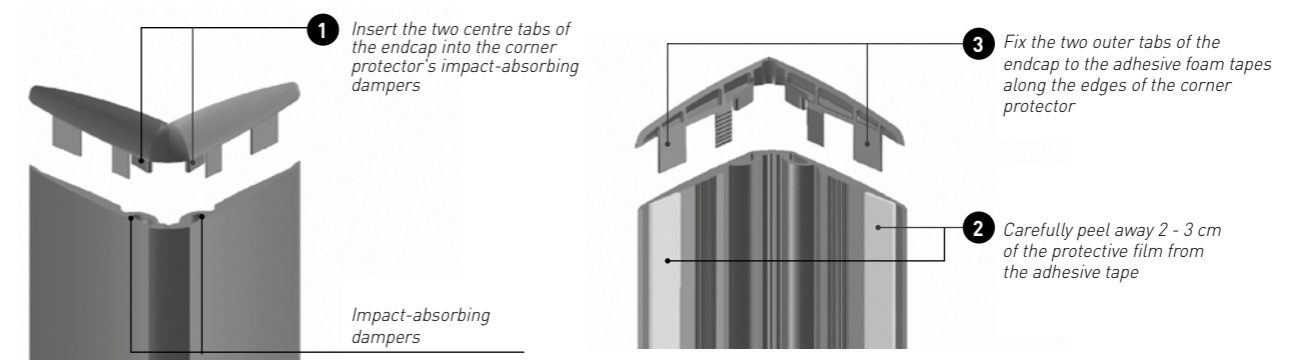

- Apply the SPM adhesive sealant to the serrated section of the profile as shown in the diagram opposite.
- Completely remove the protective film from the adhesive foam tapes.
- Place the protection against the wall.
- Press down hard (with a roller) all across the outer surface of the PVC profile.
- Clean off any excess sealant with a rag and hot water.
- Remove the protective film.

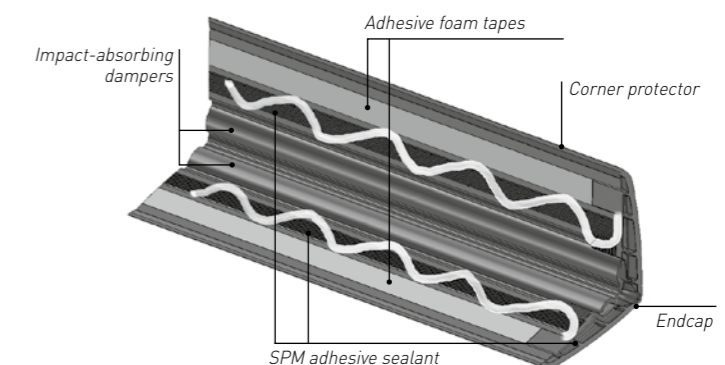

INSTALLING ELASTO'FLEX AND SAFY'CORNER

4. ELASTO'FLEX CORNER PROTECTORS

4.1 INSTALLATION PROCEDURE FOR ELASTO'FLEX CORNER PROTECTORS

- Cut the corner protector to the required length. Use a circular saw or a wide-blade knife while constantly lubricating with water or use a guillotine.
- Drill a 7 mm diameter hole in the profile at 20 mm from each edge for the screws (see diagram).
- Repeat approximately every 300 mm while ensuring that the holes are staggered.
- Use the corner protector as a template to mark and drill into the wall
- Choose the appropriate plug for the type of wall
- Fix to the wall using M5 dome-head screws fitted with washers

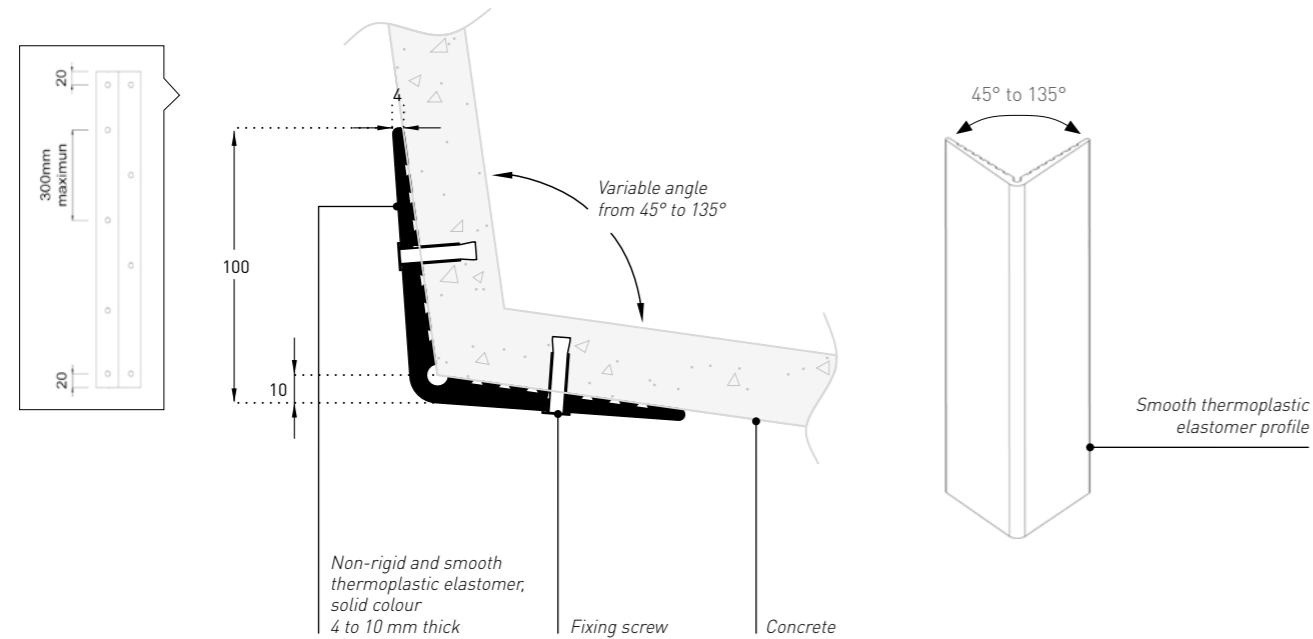

5. INDIVIDUAL PROTECTION: SAFY'CORNER AND SAFY'DOOR

5.1 INSTALLATION PROCEDURE FOR SAFY'CORNER

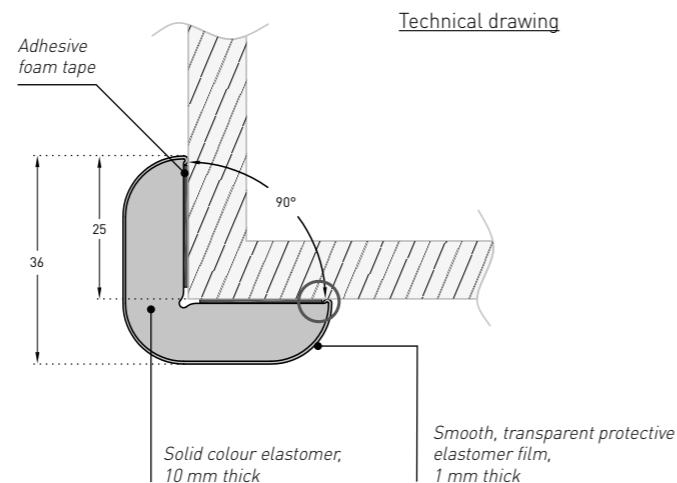

- Completely remove the protective film from the adhesive tapes.
- Place the protection against the wall.
- Press down hard (with a roller) all across the outer surface of the profile.

INSTALLING SAFY'DOOR

5.2 INSTALLATION PROCEDURE FOR SAFY'DOOR

- The product comprises two elastomer profiles that clip onto pre-drilled aluminium cores.
- Each elastomer profile snaps onto two separate cores.
- In some cases, the protector may reduce the opening angle of the door.

1. Keep the door closed.
2. Both assemblies must be positioned on the rabbet side and the hinge side as shown in the diagram opposite.

Positioning and fixing the aluminium cores:

3. Ensure that the spacing of the cores matches the dimensions of the elastomer profile. If the cores are spaced too far apart, it will be hard to install the elastomer profile.
4. Make sure that the position of the assembly does not impede the door from opening and closing.
5. Once the cores are positioned level on the door frame and door, fix the cores using screws that are suited to the type of door (woodscrews / metal screws) through the pre-drilled holes along the aluminium cores.

Placing the elastomer profile:

6. Slide the elastomer profile from top to bottom into the groove of the aluminium core.
7. Once positioned, secure the elastomer profile in the groove by slightly squeezing the lower end of the aluminium core.

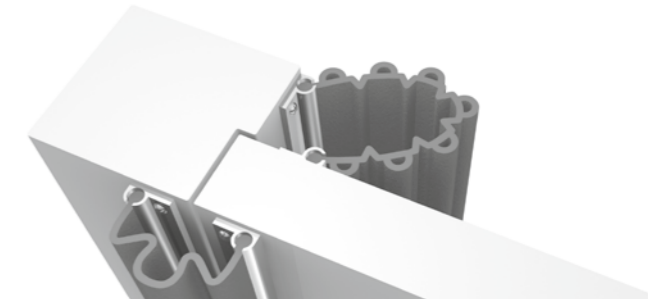

Technical drawing

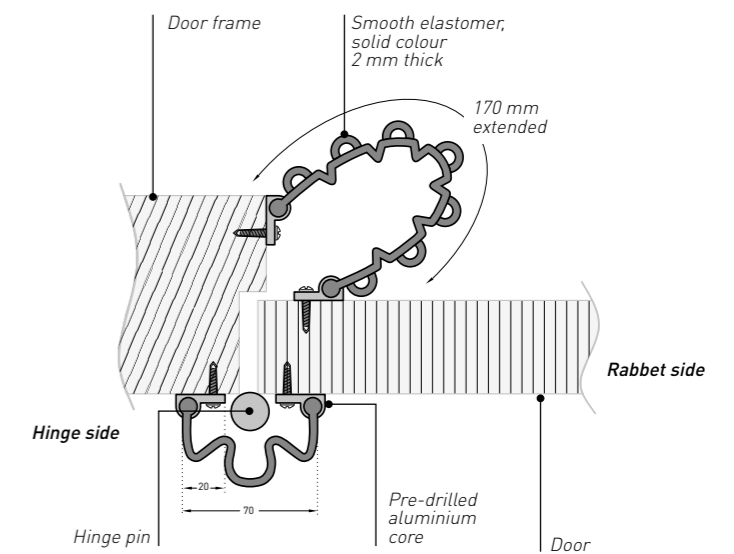

6. MAINTENANCE

Do not leave products exposed to sunlight. Excessive increases in temperature could lead to changes in colour and/or deform the product.

The following products are recommended for cleaning:

- | | | |
|-----------|---------------------|--|
| - Ammonia | - Isopropyl alcohol | - Standard cleaning products, such as Bioquell and Anios |
| - Ethanol | - Essence F cleaner | |

It is essential to use solvents that do not leave any greasy or dry residue.

- Products MUST NOT BE CLEANED with a scouring pad, such as a Scotch-Brite pad.

DO NOT USE:

- White spirit
- Acetone
- Petrol
- Paint thinners

If using non-recommended products, test on an offcut. Reactions may differ depending on the colour of the product and the solvents used.

INSTALLING HANDRAILS

1. TOOLS REQUIRED	33
2. METHODS FOR FIXING HANDRAILS	33
3. INSTALLATION PROCEDURE	33/35
3.1 Measuring and cutting aluminium and PVC profiles to length.....	34
3.2 Cutting aluminium and PVC lengths and cutting to measure accessories.....	35
3.3 Fixing handrails on DECOCHOC panels.....	35
4. ESCORT HANDRAILS	35/39
4.1 Presentation of the different brackets available for ESCORT handrails	35
4.2 Presentation and assembly of the different accessories for ESCORT handrails.....	36
4.3 Preparing ESCORT handrails.....	39
4.4 Fixing ESCORT handrails	39
5. LINEA'TOUCH AND TOUCH+ HANDRAILS	41/43
5.1 Presentation and assembly of the different accessories for LINEA'TOUCH and TOUCH+ handrails	41
5.2 Preparing LINEA'TOUCH and TOUCH+ handrails	42
5.3 Fixing LINEA'TOUCH and TOUCH+ handrails.....	43
6. STARLINE HANDRAILS	45/47
6.1 Presentation and assembly of the different accessories for STARLINE handrails.....	45
6.2 Preparing STARLINE handrails.....	46
6.3 Fixing STARLINE handrails	47
7. ESCORT'DUO AND LINEA'DUO HANDRAILS	48/49
7.1 Presentation and assembly of the different accessories for ESCORT'DUO and LINEA'DUO handrails.....	48
7.2 Preparing ESCORT'DUO and LINEA'DUO handrails	48
7.3 Fixing ESCORT'DUO and LINEA'DUO handrails.....	49
8. PERFORMER 2 HANDRAILS	51/53
8.1 Presentation and assembly of the different accessories for PERFORMER 2 handrails.....	51
8.2 Preparing PERFORMER 2 handrails.....	51
8.3 Fixing PERFORMER 2 handrails	53
9. INTERNAL, EXTERNAL AND MADE-TO-MEASURE ANGLE PIECES	55
10. ADJUSTMENT SHIM FOR ESCORT, STARLINE, LINEA'TOUCH AND TOUCH+ HANDRAILS	56
11. INSTALLING HANDRAILS WITH THE SERVICE DUCT KIT	56
12. INSTALLING CURVED HANDRAILS	59
13. MAINTENANCE	59

1. TOOLS REQUIRED

- Sliding mitre saw and carbide blade for aluminium/PVC
E.g. FESTOOL KS 88E saw – Blade reference TF52
- Measuring tape and pencil
Reference: ROMUS 93290 and 93185
- Electric drill and screwdriver
- Angle finder
Reference: ROMUS 93230
- Rigid PVC glue, such as TANGIT - U
- Pop rivets or 3 mm self-tapping screws
- Rivet gun
- 2 mm, 2.5 mm and 3 mm Allen keys
- Laser level

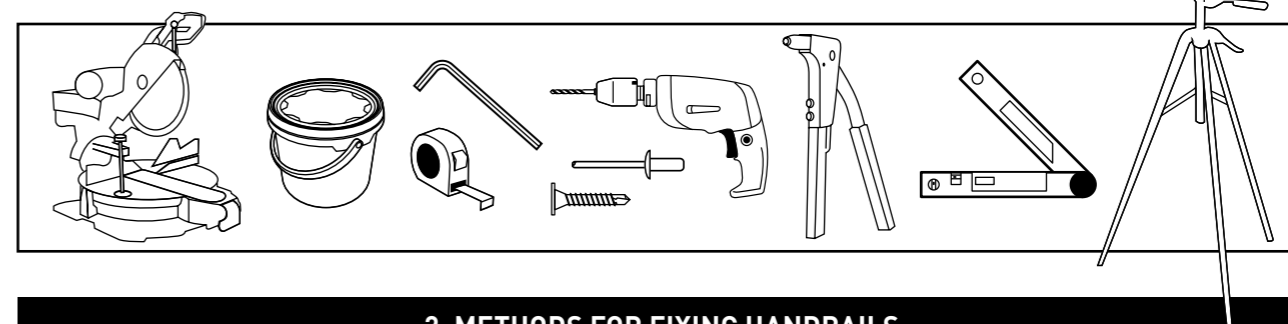

2. METHODS FOR FIXING HANDRAILS

The table below shows the recommended fixing techniques to be used for the main types of wall surface found in the building industry.

These techniques apply to all SPM handrails.

TYPE OF WALL	FIXING PROCEDURE
WALLS WITH WOODEN STUDS	Woodscrews, 6 mm
METALLIC STRUCTURES	Self-tapping screws, 6 mm
PLASTERBOARD (SINGLE SKIN), HOLLOW BRICK, HOLLOW BREEZE BLOCK*	Metal expansion plugs, 6 mm
PLASTERBOARD (DOUBLE SKIN)	Metal expansion plugs, 6 mm
CONCRETE WALLS	FISCHER-type plugs, 8 mm diameter for 6 mm screws
SOLID BRICK AND OLD WALLS	FISCHER-type plugs, 8 mm diameter for 6 mm screws
HOLLOW PLASTER TILES, CELLULAR CONCRETE	FISCHER-type plugs, 8 mm diameter for 6 mm screws

[*] If the area is subject to heavy traffic, add an extra wood or metal stud in the partition to withstand a vertical and horizontal pressure level of 100 kg between two brackets. If installing the handrail on a single-skin plasterboard wall (such as Gypsum), add wood or metal reinforcements according to the supplier's recommendations. With ESCORT, LINEA'TOUCH and STARLINE handrails, use countersinking screws. With PERFORMER 2, ESCORT'DUO and LINEA'DUO handrails, use flange head screws (flat head) with a 12 mm flange diameter.

3. INSTALLATION PROCEDURE

The procedure below describes the quickest and easiest way to install SPM handrails. In principle, there are two major stages:

- Measure and cut the profiles to length
- Prepare and fix the handrails

The first stage is common to all SPM handrail models.

The second stage is specific to each handrail model.

INSTALLING HANDRAILS

3.1 MEASURING AND CUTTING ALUMINIUM AND PVC PROFILES TO LENGTH

- Measure each section of wall in order to cut and prepare the lengths of handrail before installation.
- At each end of the handrail, allow a clearance of at least 30 mm between the end of the handrail (with its wall return) and the edge of the wall or door frame. This clearance allows the wall return to be removed if it has to be replaced.

Example of measuring a straight wall section:

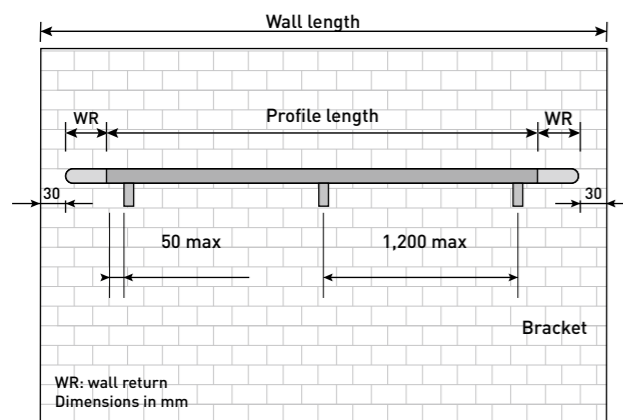

Example of measuring a wall with an internal / external angle:

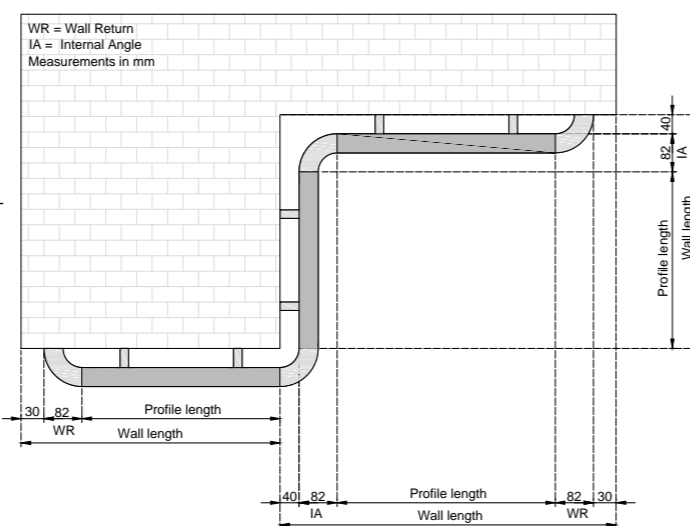

Based on the measurement of the wall after subtracting the necessary clearance of 30 mm on the side(s), use the table below to calculate the cutting lengths of the aluminium and PVC profiles based on the various wall returns and internal / external angle pieces used:

HANDRAIL	ENDCAP	FLAT ENDCAP	BEVELLED ENDCAP	WALL RETURN	EXTENDED AND CURVED WALL RETURN	INTERNAL / EXTERNAL ANGLE PIECE
ESCORT	PVC & Alu: - 22 mm	PVC & Alu: - 4 mm	-	PVC & Alu: - 82 mm	-	PVC & Alu: Internal: - 122 mm External: - 2 mm
STARLINE	PVC & Alu: - 17 mm	-	-	PVC & Alu: - 85 mm	-	PVC & Alu: Internal: - 132 mm External: - 2 mm
PERFORMER 2	PVC: - 7 mm Alu: - 16 mm	-	-	PVC: - 106 mm Alu: - 86 mm	-	External PVC: + 3 mm External Alu: + 23 mm
LINEA TOUCH AND TOUCH+	PVC & Alu: - 12 mm	-	PVC & Alu: - 25 mm	PVC & Alu: - 82 mm	PVC & Alu: - 188 mm	PVC & Alu: Internal: - 122 mm External: 0 mm
ESCORT DUO LINEA DUO	PVC: - 27 mm Alu: - 35 mm	-	-	PVC: - 97 mm Alu: - 105 mm	-	Internal PVC: - 144.5 mm External Alu: - 152.5 mm External: - 2 mm

(the values include the dimensions of the joints)

INSTALLING HANDRAILS

3.2 CUTTING ALUMINIUM AND PVC LENGTHS AND CUTTING TO MEASURE ACCESSORIES

- Once the lengths of the aluminium and PVC profiles have been calculated, cut the profiles to length using a mitre saw and a suitable blade (preferably a fine-toothed blade in order to avoid splinters). Recommended blades feature alternating flat teeth and trapezoidal teeth. Refer to "Tools Required".



- For a better finish, saw the aluminium and PVC profiles to length while they are snap-fixed together and held from one side. Preferably cut while pushing the sliding saw.
- Made-to-measure angle pieces can be cut with a mitre saw. Mount the angle piece onto a section of profile to hold it steady while cutting and thereby maximise safety.
- Make sure that you position the angle piece correctly to cut it "on the radius". A slightly oblique cut will cause mounting problems by altering the dimensions of the contact surfaces.

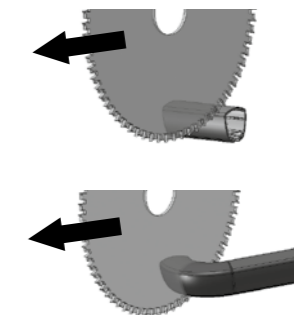

3.3 FIXING HANDRAILS ON DECOCHOC PANELS

- Handrail brackets can only be fixed to DECOCHOC panels where temperature conditions are perfectly stable (otherwise the brackets could prevent the panels from expanding, causing them to come away from the wall).

4. ESCORT HANDRAILS

4.1 PRESENTATION OF THE DIFFERENT BRACKETS AVAILABLE FOR ESCORT HANDRAILS

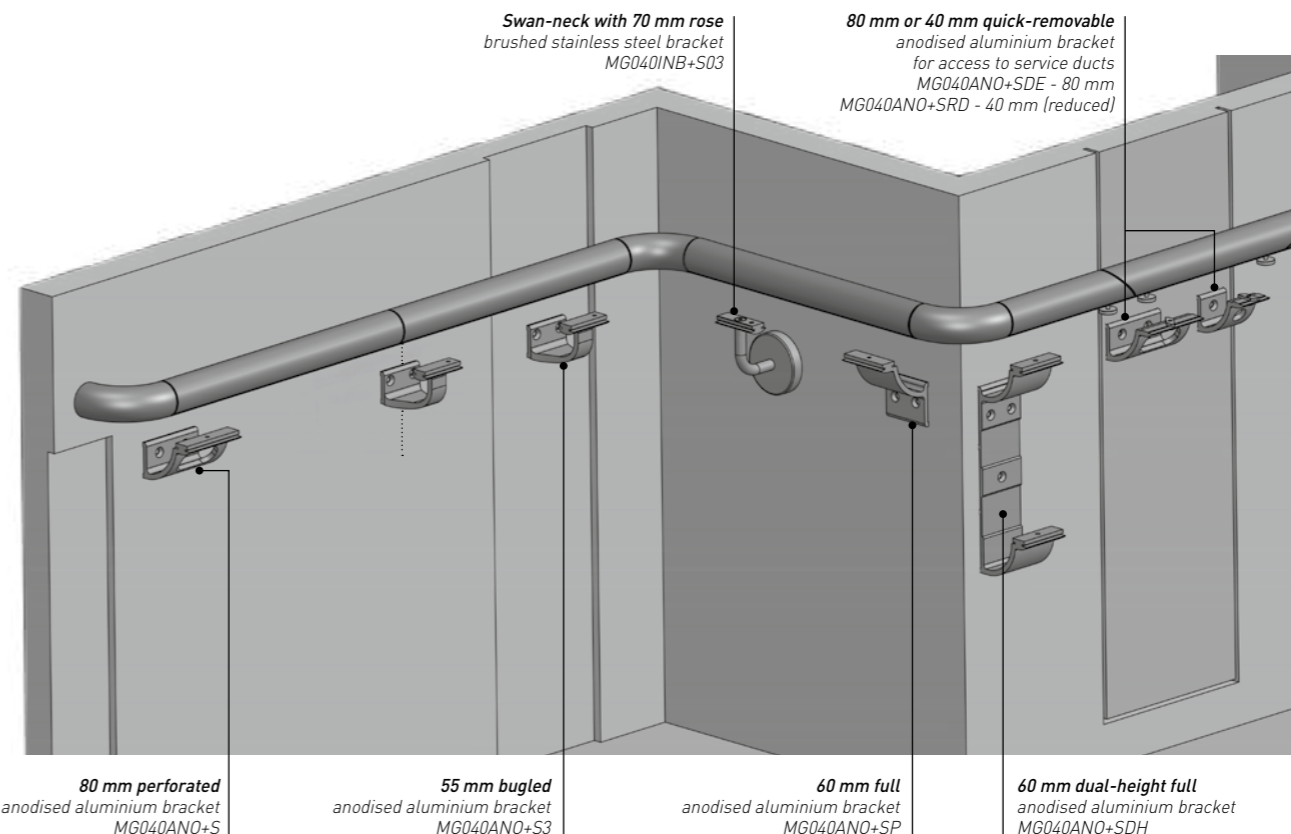

INSTALLING ESCORT

4.2 PRESENTATION AND ASSEMBLY OF THE DIFFERENT ACCESSORIES FOR ESCORT HANDRAILS

Joining piece for straight lengths

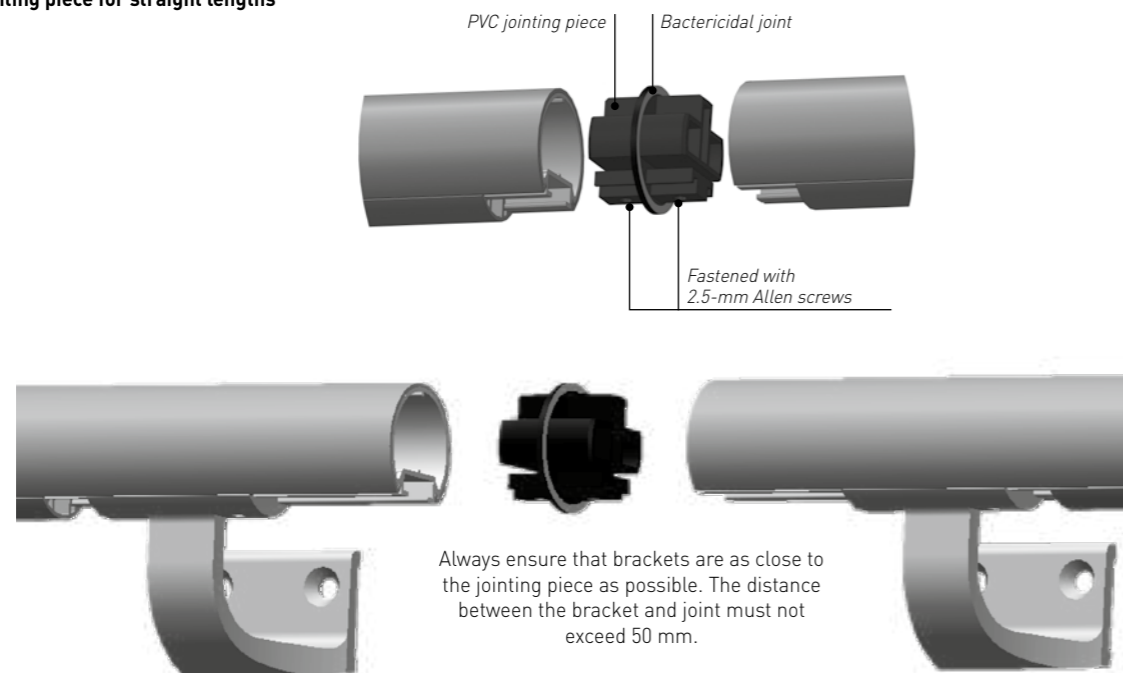

Joining internal / external angle pieces with straight lengths

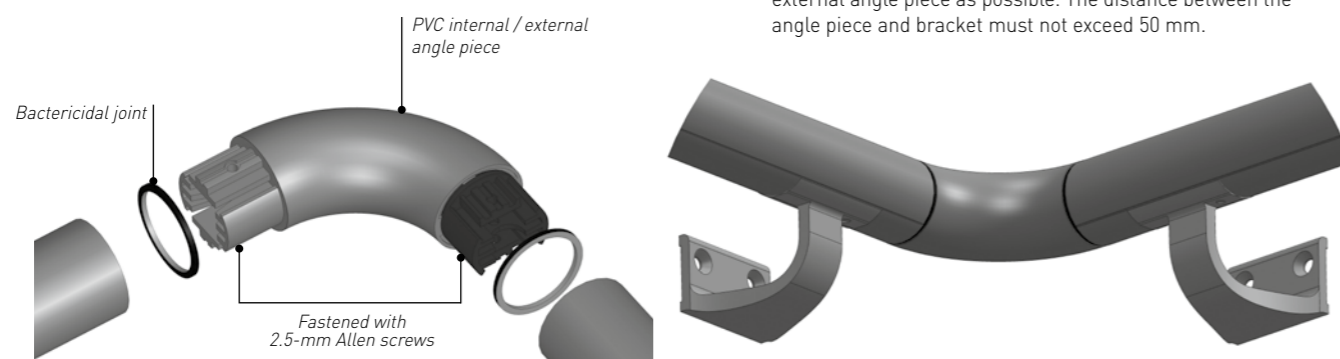

Joining made-to-measure angle pieces with straight lengths

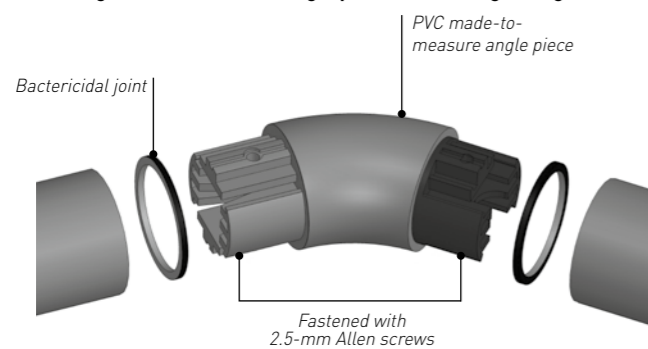

INSTALLING ESCORT

Joining endcaps / flat endcaps and wall returns with straight lengths

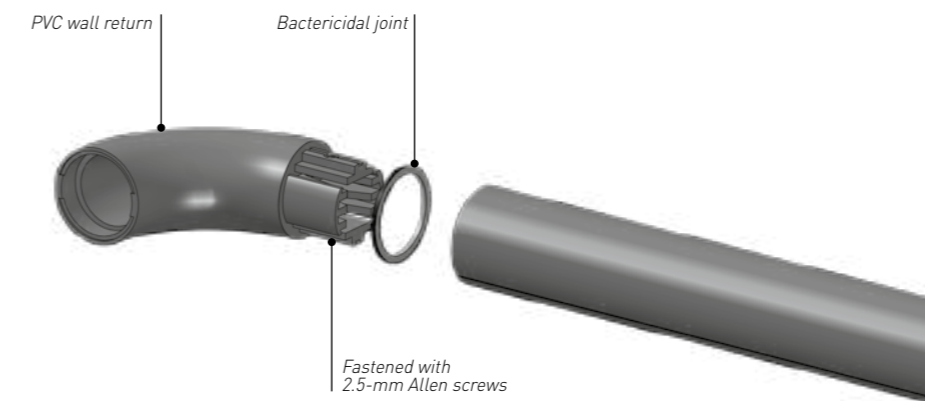
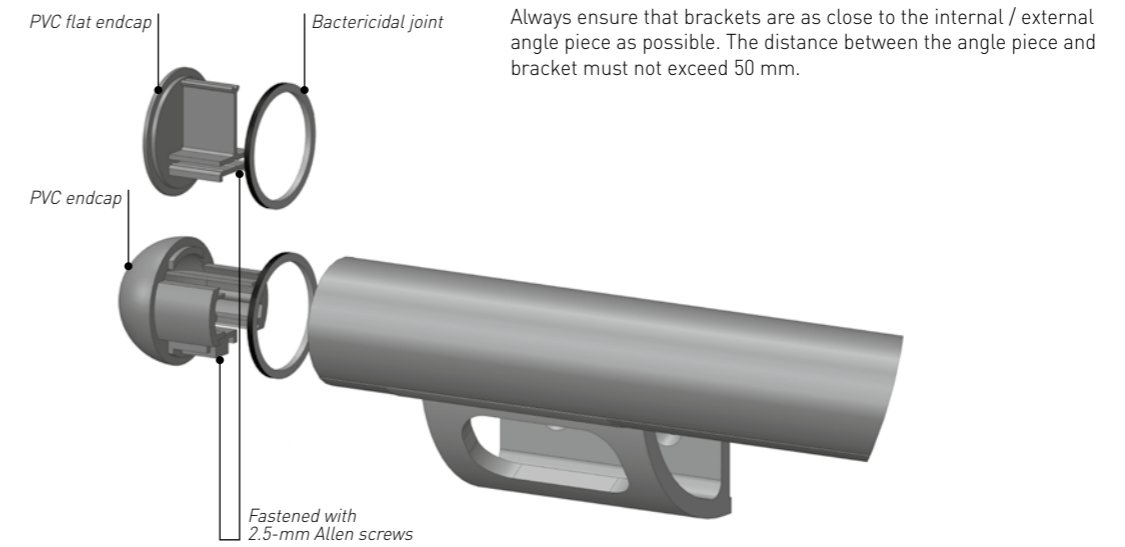

Fitting blanking plugs

Blanking plugs are used in sectors with stringent hygiene requirements and provide a bactericidal finish for wall returns.



INSTALLING ESCORT

Fitting support washers (optional)

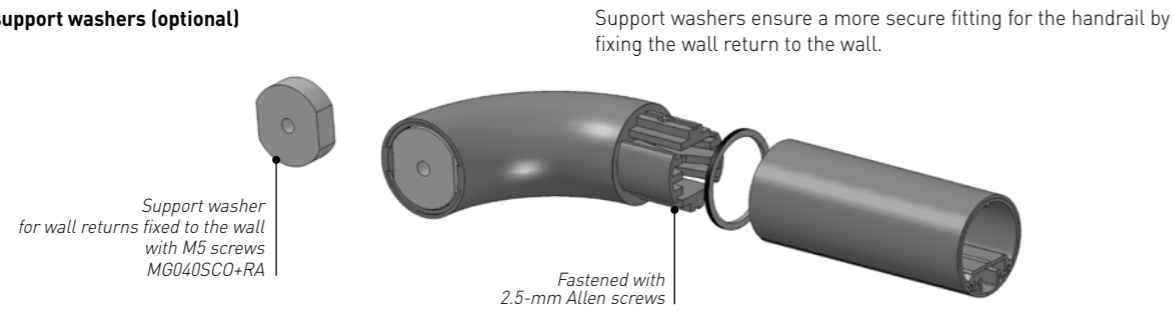

Fitting slope links / angled slope links and Rapid'Angle (for staircases)

Always ensure that brackets are as close to the internal / external angle piece as possible. The distance between the angle piece and bracket must not exceed 50 mm.

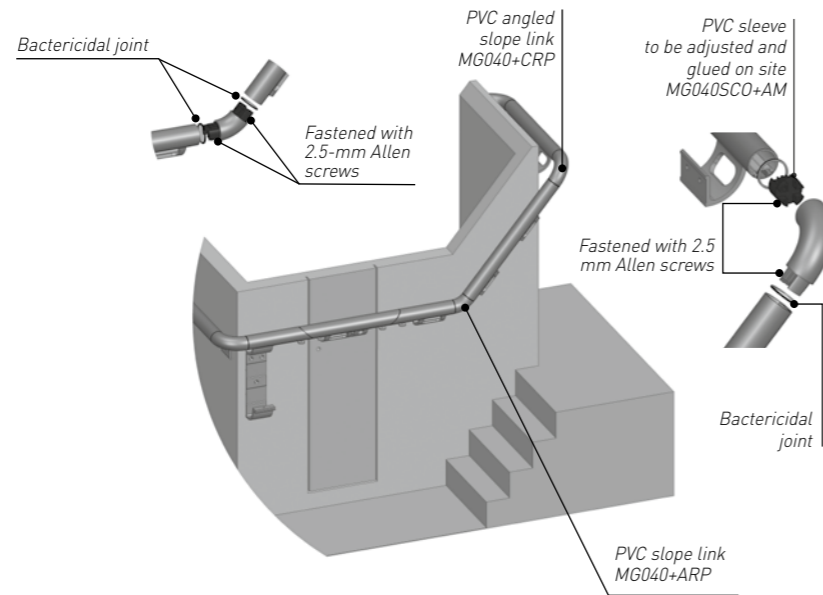

Always ensure that brackets are as close to the angle pieces as possible. The distance between the angle piece and bracket must not exceed 50 mm.

Rapid'Angle: adapts to every angle between 80 and 180° without exception

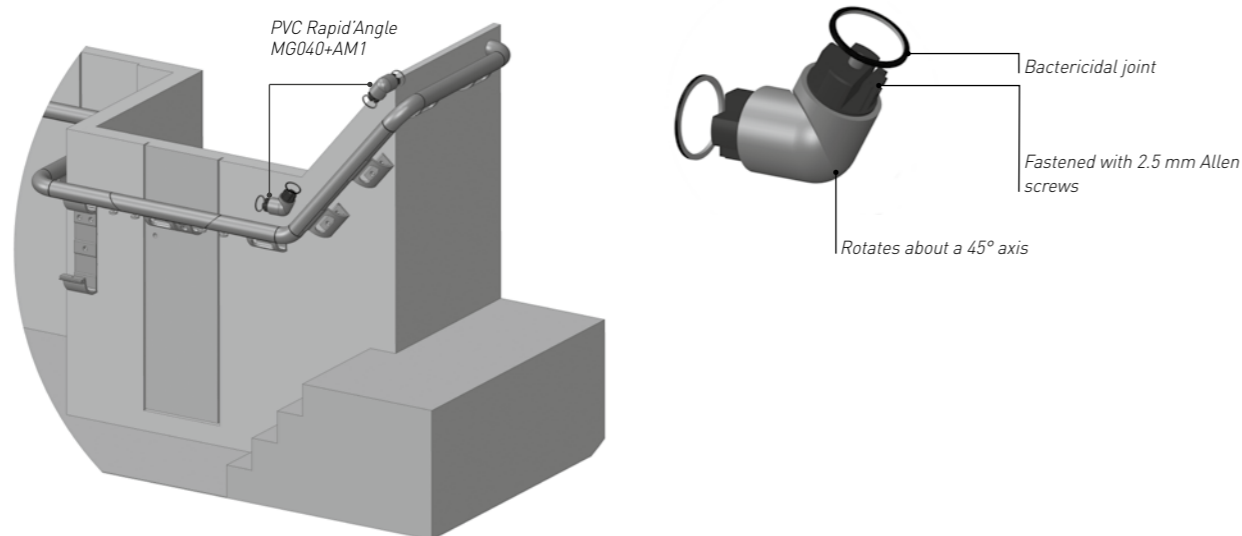

INSTALLING ESCORT

4.3 PREPARING ESCORT HANDRAILS

Refer to Sections 3.1 and 3.2 on how to calculate the cutting lengths for the profiles. Once the profiles have been cut to length:

- Slide the brackets into the groove of the aluminium profile.

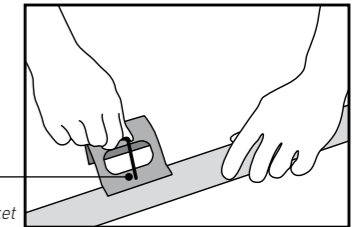

- Position the end brackets at no more than 50 mm from the end of the profile.
- Set the brackets at maximum intervals of 1,200 mm.
- For short handrail lengths, use at least two brackets at even intervals.
- Fix the brackets to the aluminium profile using a 2.5 mm Allen key.
- Then insert the accessories (endcaps, wall returns, jointing pieces, etc.) into the profile and secure with the pre-fitted screws until they are flush and hold the accessory in place.
- Finally, cut the closer to the required lengths and clip into the profile groove.

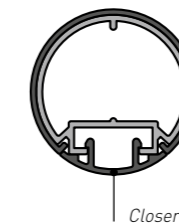

4.4 FIXING ESCORT HANDRAILS

- Once the handrail lengths have been prepared, together with their endcaps, wall returns, brackets and closers, mount them to their respective wall sections.
- For a handrail height of 900 mm from the floor, use a pencil (or laser) to draw a mark at the required height. The table below shows the drilling heights according to the ESCORT brackets used:

TYPE OF BRACKET	POSITION OF THE MARK FOR A HANDRAIL HEIGHT AT 900 M
80 mm perforated bracket MG040ANO+S	845 mm
55 mm bugled bracket MG040ANO+S3	845 mm
60 mm full bracket MG040ANO+SP	810 mm
55 mm bugled bracket MG040ANO+S3C	845 mm
60 mm dual-height full bracket MG040ANO+SDH	800 mm - 725 mm
80 mm quick-removable perforated bracket MG040ANO+SDE	845 mm
40 mm quick-removable reduced bracket MG040ANO+SDR	845 mm
Swan-neck with 70 mm rose MG040INB+S03	821 mm - 786 mm

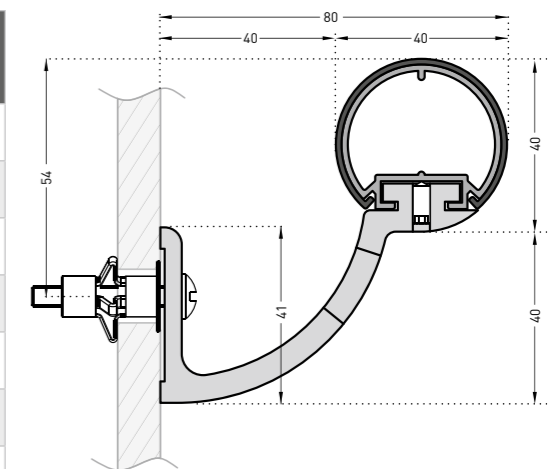

80 mm perforated bracket MG040ANO+S

INSTALLING ESCORT

- Hold the handrail against the wall, leaving a space of 30 mm from the edge of the wall, and place the holes drilled in the brackets over the marks.
- Position the first bracket for each end as close as possible to each finishing accessory (the first bracket should be no more than 50 mm from the finishing accessory).
- Each handrail must be mounted to the wall with at least two brackets.
- If several brackets need to be installed, space them at intervals of no more than 1,200 mm (800 mm intervals in heavy-traffic areas or on lighter wall surfaces, such as plasterboard).
- Use a spirit level to check that the handrail is horizontal and then mark the holes to be drilled for each bracket on the wall.
- Now use a suitable drill bit to drill into the wall. The diameter of the drilled hole may vary according to the type of wall (refer to the methods for installing handrails in Section 2).
- When drilling in clean environments, you are advised to use an extractor system connected to the drill to effectively collect all the dust.
- Once all the holes have been drilled, fix the handrail brackets to the wall, starting with the two end brackets.

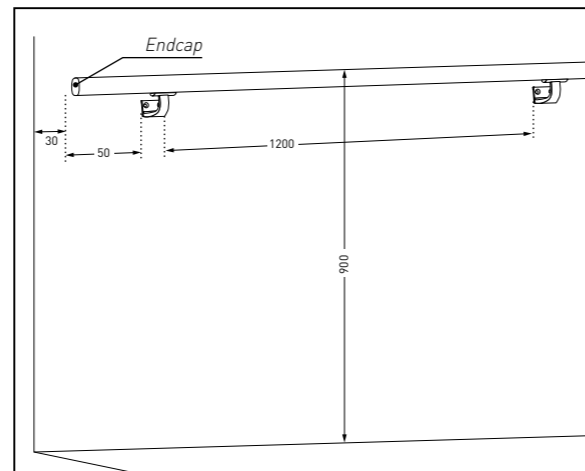

Access to
LINEA'TOUCH
handrail
installation video

INSTALLING LINEA'TOUCH AND TOUCH+

5. LINEA'TOUCH AND TOUCH+ HANDRAILS

5.1 PRESENTATION AND ASSEMBLY OF THE DIFFERENT ACCESSORIES FOR LINEA'TOUCH AND TOUCH+ HANDRAILS

Presentation

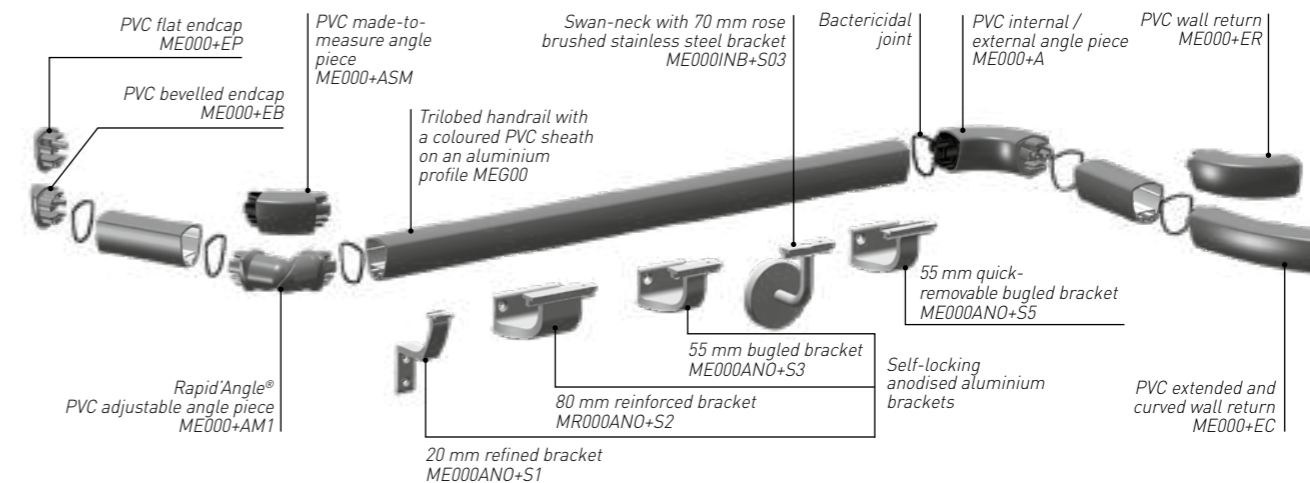

Joining wall returns with straight lengths

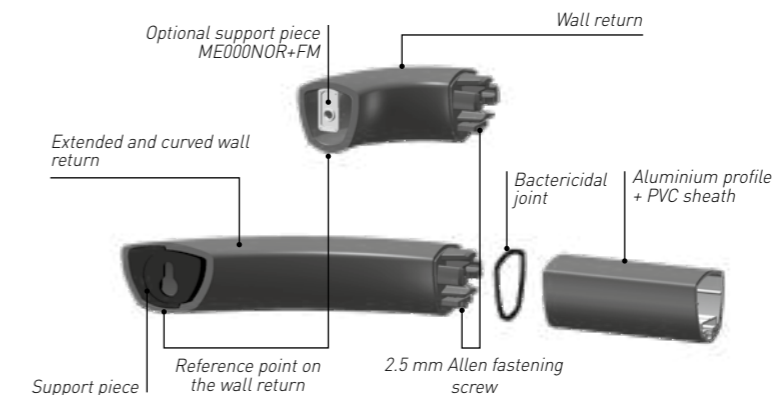

- Extended and curved wall returns must be fitted with wall-mounted support pieces.
- Once the wall return has been assembled and the handrail fixed, use the mark beneath the wall return as a reference point for drilling the hole. Once the mark has been pencilled on the wall, remove the wall return from the handrail and mark a point 22 mm vertically above the reference point as the centre for the hole to be drilled.
- Drill, plug and screw the support piece to the wall. Place the wall return on the support piece and then reassemble with the handrail.
- The support piece is always supplied with extended and curved wall returns. It is available as an optional extra with standard wall returns (the procedure is the same, regardless of the wall return used).

Joining endcaps with straight lengths

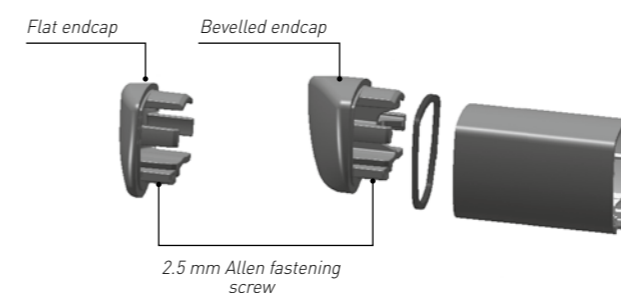

Joining straight lengths

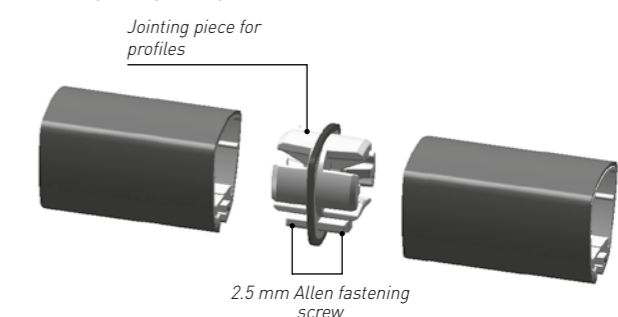



INSTALLING LINEA'TOUCH AND TOUCH+

Joining angle pieces with straight lengths



Joining made-to-measure angle pieces with straight lengths

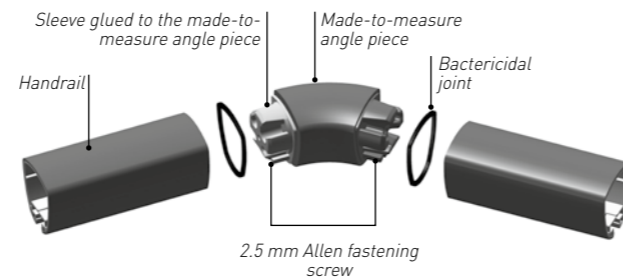

5.2 PREPARING LINEA'TOUCH AND TOUCH+ HANDRAILS

Refer to Sections 3.1 and 3.2 on how to calculate the cutting lengths for the profiles.

Once the profiles have been cut to length:

- Slide the brackets into the groove of the aluminium profile.
- Position the end brackets at no more than 50 mm from the end of the profile.
- Set the brackets at maximum intervals of 1,200 mm.
- For short handrail lengths, use at least two brackets at even intervals.
- Fix the brackets to the aluminium profile using a 2.5 mm Allen key.
- Then insert the accessories (endcaps, wall returns, jointing pieces, etc.) into the profile and secure with the pre-fitted screws until they are flush and hold the accessory in place.

LINEA'TOUCH

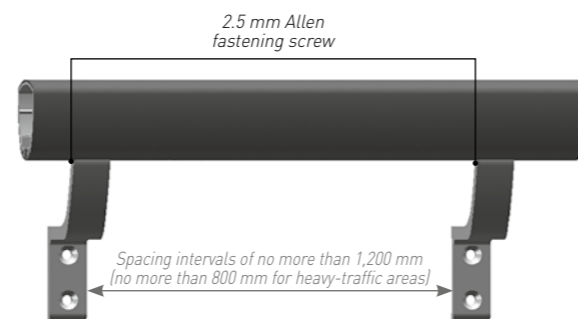
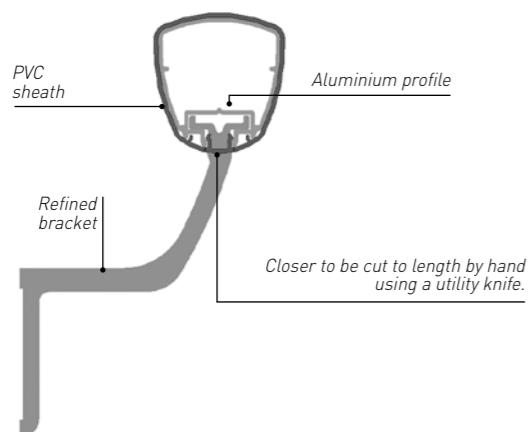

LINEA'TOUCH+

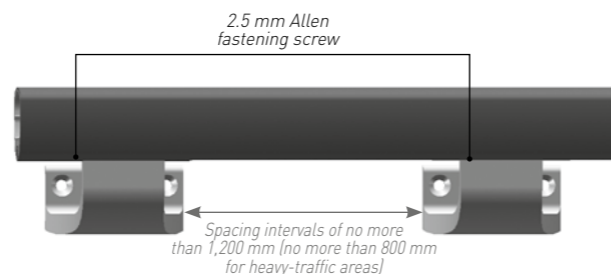
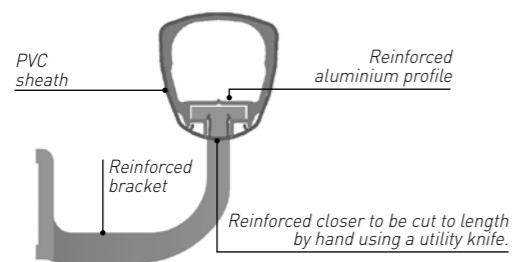

INSTALLING LINEA'TOUCH AND TOUCH+

- Finally, cut the closer to the required lengths and clip into the profile groove.
- If the closer is positioned at the end against a wall return, angle piece or jointing piece, it will need to be trimmed to reduce its height. Using a utility knife, cut the closer over a length of 15 mm.

5.3 FIXING LINEA'TOUCH AND TOUCH+ HANDRAILS

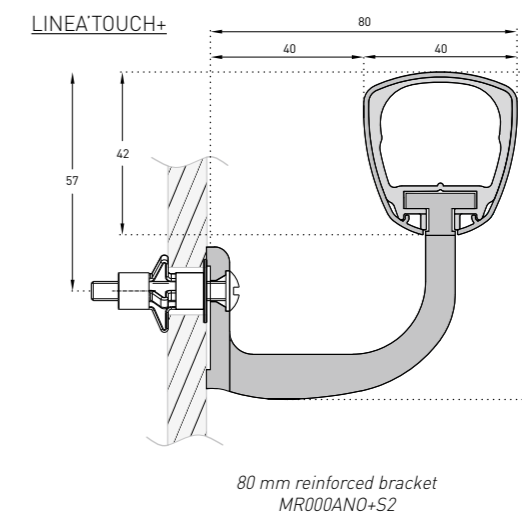
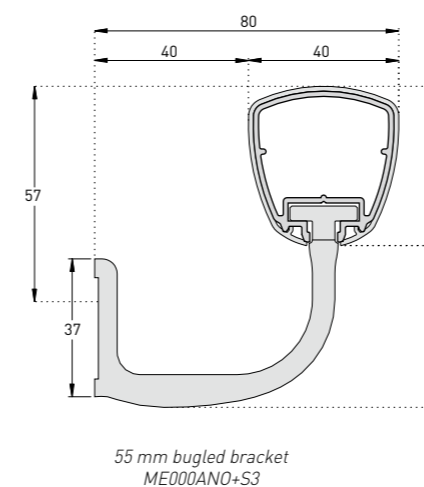
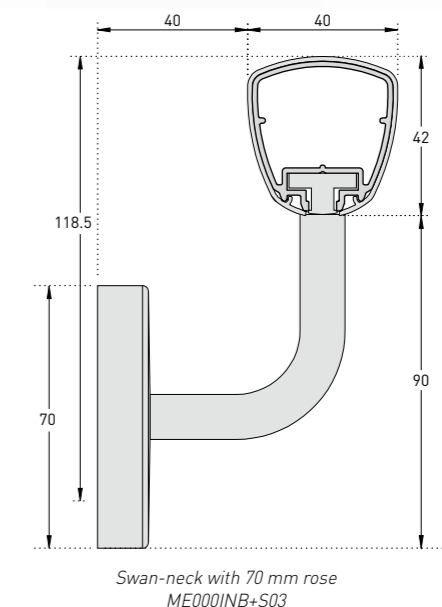
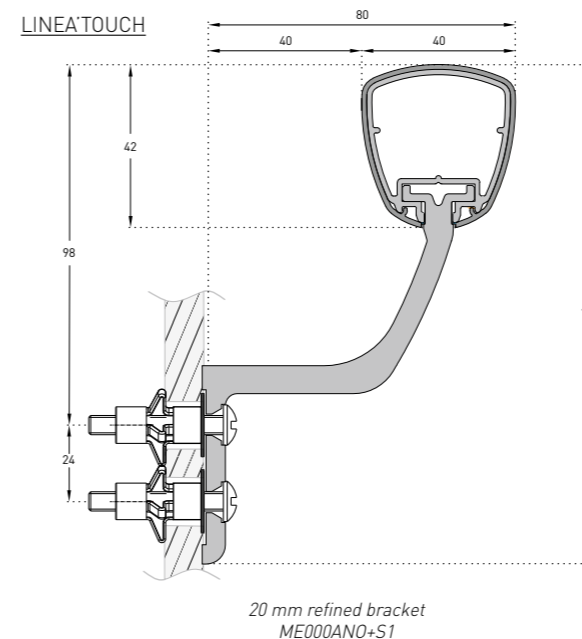

For a handrail height of 900 mm:

TYPE OF BRACKET	POSITION OF THE MARK FOR A HANDRAIL HEIGHT AT 900 MM
20 mm refined bracket ME000ANO+S1	802 mm - 778 mm
80 mm reinforced bracket MR000ANO+S2	843 mm
55 mm bugled bracket ME000ANO+S3	843 mm
Swan-neck with 70 mm rose ME000INB+S03	816.5 mm - 781.5 mm
55 mm quick-removable bugled bracket ME000ANO+S5	843 mm

INSTALLING LINEA'TOUCH AND TOUCH+

- Hold the handrail against the wall, leaving a space of 30 mm from the edge of the wall, and place the holes drilled in the brackets over the marks.

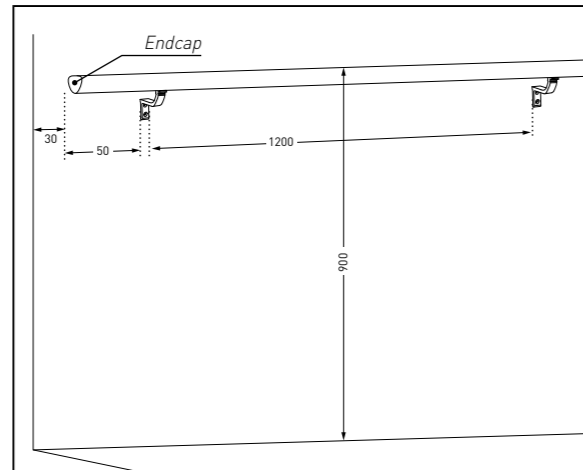

- Position the first bracket for each end as close as possible to each finishing accessory (the first bracket should be no more than 50 mm from the finishing accessory).
- Each handrail must be mounted to the wall with at least two brackets.
- If several brackets need to be installed, space them at intervals of no more than 1,200 mm (800 mm intervals in heavy-traffic areas or on lighter wall surfaces, such as plasterboard).
- Use a spirit level to check that the handrail is horizontal and then mark the holes to be drilled for each bracket on the wall.
- Now use a suitable drill bit to drill into the wall. The diameter of the drilled hole may vary according to the type of wall (refer to the methods for installing handrails in Section 2).
- When drilling in clean environments, you are advised to use an extractor system connected to the drill to effectively collect all the dust.
- Once all the holes have been drilled, fix the handrail brackets to the wall, starting with the two end brackets.

INSTALLING STARLINE

6. STARLINE HANDRAILS

6.1 PRESENTATION AND ASSEMBLY OF THE DIFFERENT ACCESSORIES FOR STARLINE HANDRAILS

Presentation

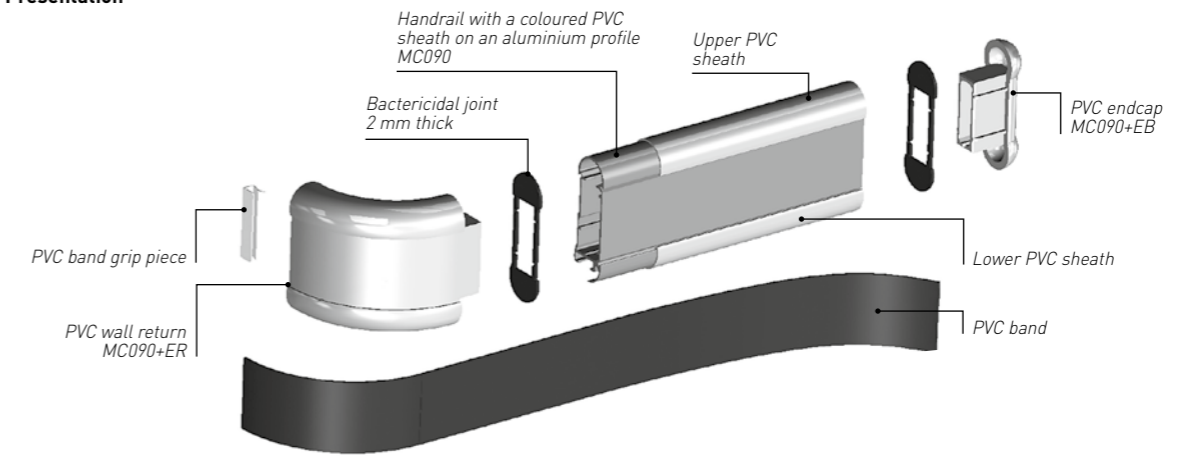

Self-locking anodised aluminium brackets

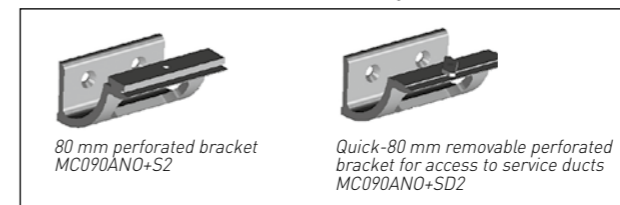

Joining made-to-measure angle pieces to straight lengths

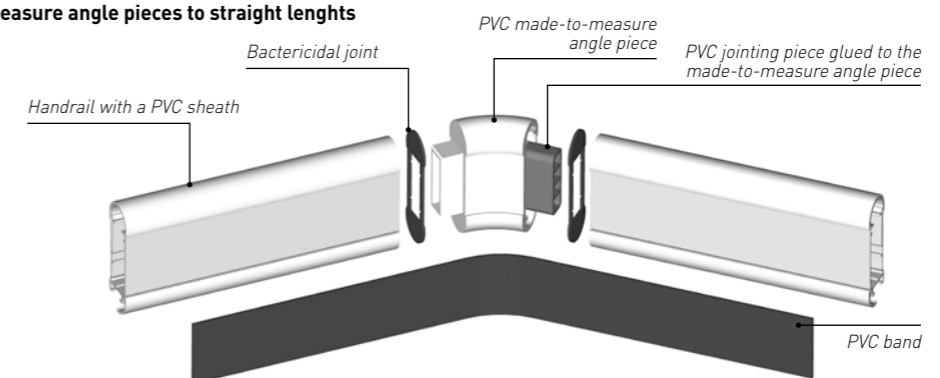

Joining straight lengths

Jointing pieces are used to maintain stability and ensure a continuous geometric finish between two straight handrail lengths.

STARLINE jointing pieces comprise two parts that are quick and easy to fit:

- A 100 mm-long assembly wedge for joining handrails.
- A jointing piece for aligning handrail lengths.

In case of a STARLINE handrail with a PVC sheath, offset the ends of the aluminium profiles and PVC sheaths to conceal any clearances.

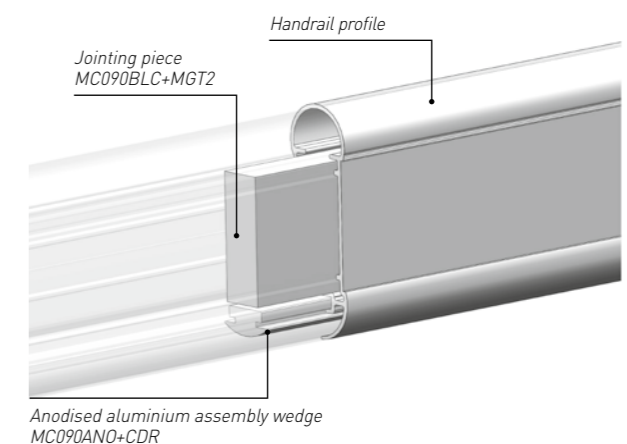

INSTALLING STARLINE

6.2 PREPARING STARLINE HANDRAILS

Refer to Sections 3.1 and 3.2 on how to calculate the cutting lengths for the profiles. Once the profiles have been cut to length:

- Slide the brackets into the groove of the aluminium profile.
- Position the end brackets at no more than 50 mm from the end of the profile.
- Set the brackets at maximum intervals of 1,200 mm.
- For short handrail lengths, use at least two brackets at even intervals.
- Fix the brackets to the aluminium profile using a 2.5 mm Allen key.
- Then insert the accessories (endcaps, wall returns, jointing pieces, etc.) into the profile and secure with the pre-fitted screws until they are flush and hold the accessory in place.
- Assemble the profile and accessories using a self-tapping screw or 3 mm diameter rivet.

Position the screw or rivet 10 mm from the end.

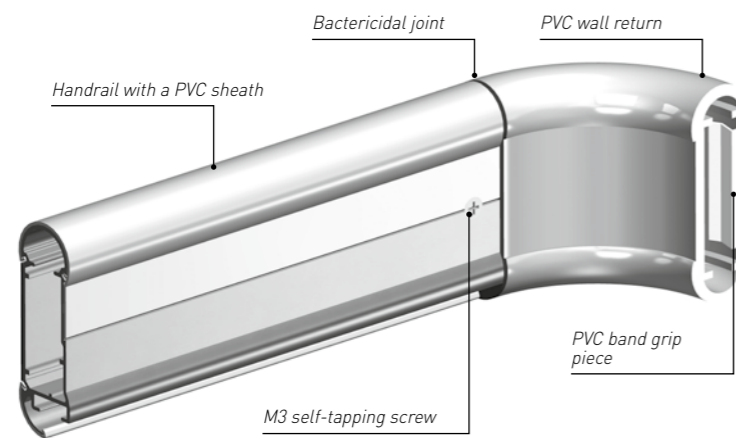

- For anodised and PVC sheathed STARLINE handrails, fix the flexible adhesived PVC band along the whole length of the profile and accessories. A band grip piece must be used to secure the band at the end of the accessory.
- Press down hard (with a roller) all along the length.

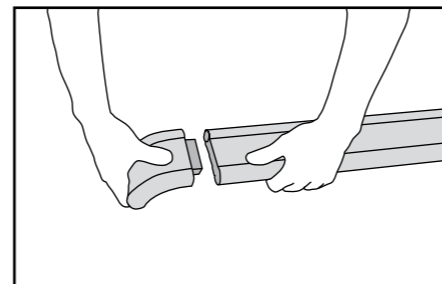
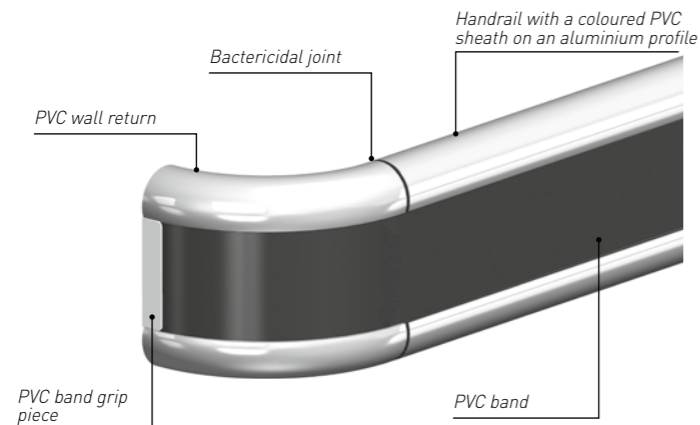

INSTALLING STARLINE

6.3 FIXING STARLINE HANDRAILS

- Once the handrail lengths have been prepared, together with their wall returns and brackets, fix them to their respective wall sections.
- For a handrail height of 900 mm from the floor, use a pencil (or laser) to draw a mark at the required height. The table opposite shows the drilling heights according to the STARLINE brackets used:

TYPE OF BRACKET	POSITION OF THE MARK FOR A HANDRAIL HEIGHT AT 900 MM
80 mm perforated bracket MC090ANO+S2	800 mm
80 mm quick-removable perforated bracket MC090ANO+SD2	800 mm

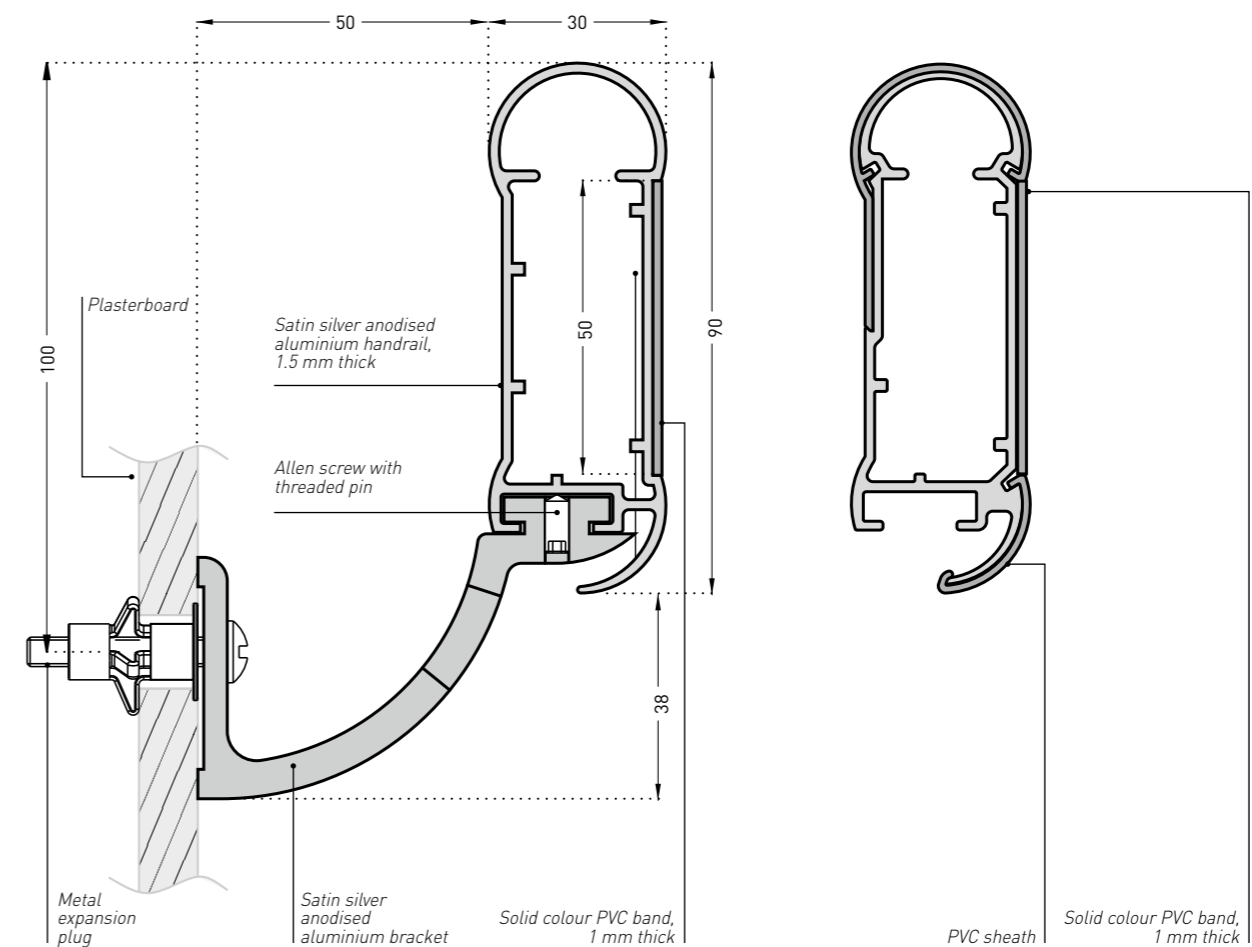

- Once each wall section has been marked out, fix the handrail to the wall using the method shown for ESCORT handrails (Section 4.4).

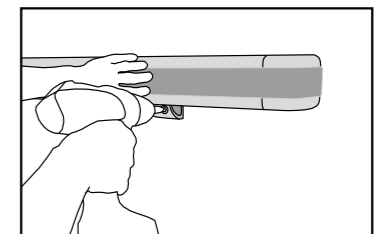

INSTALLING ESCORT'DUO AND LINEA'DUO

INSTALLING ESCORT'DUO AND LINEA'DUO

7. ESCORT'DUO AND LINEA'DUO HANDRAILS

7.1 PRESENTATION AND ASSEMBLY OF THE DIFFERENT ACCESSORIES FOR ESCORT'DUO AND LINEA'DUO HANDRAILS

Presentation

ESCORT'DUO

LINEA'DUO

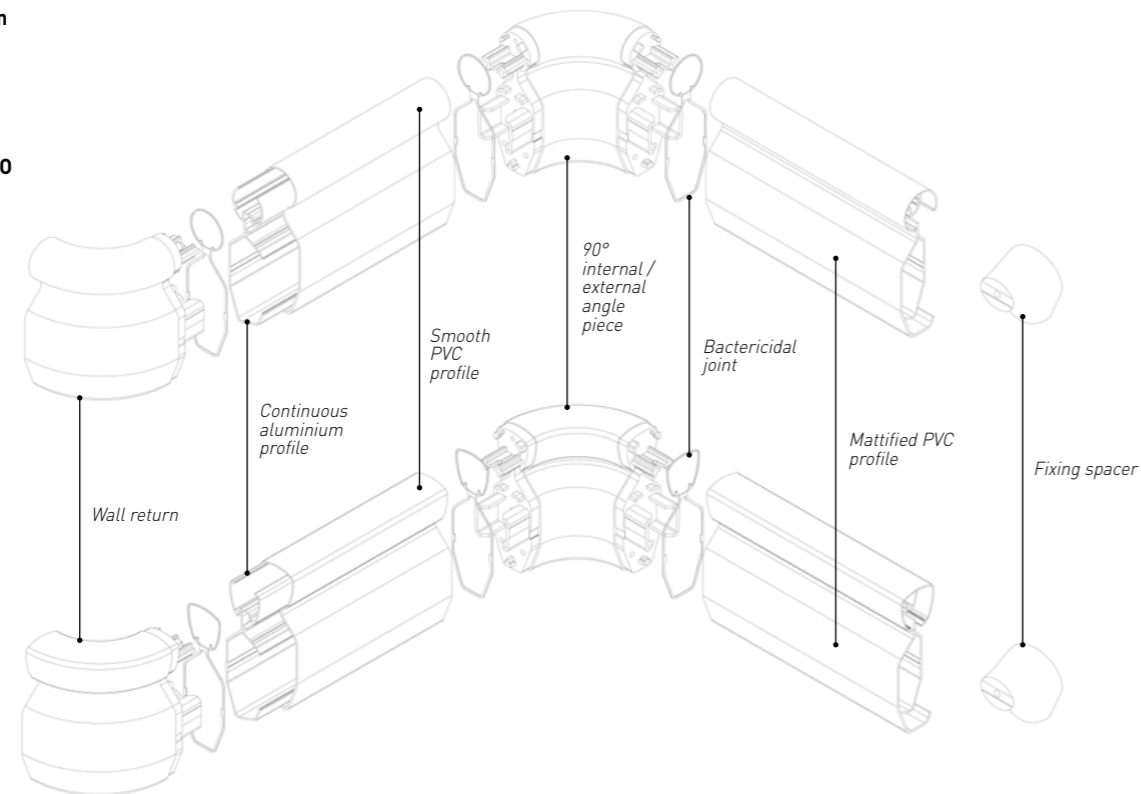

7.2 PREPARING ESCORT'DUO AND LINEA'DUO HANDRAILS

Refer to Sections 3.1 and 3.2 on how to calculate the cutting lengths for the profiles. Once the profiles have been cut to length:

- First drill the holes in the grooved line of the aluminium rail for the fixing spacers near the endcaps and / or wall returns and / or internal / external angle pieces. The distance must not exceed 100 mm. Then drill the holes for the fixing spacers every 800 mm to 1,000 mm depending on the expected level of traffic in the area.

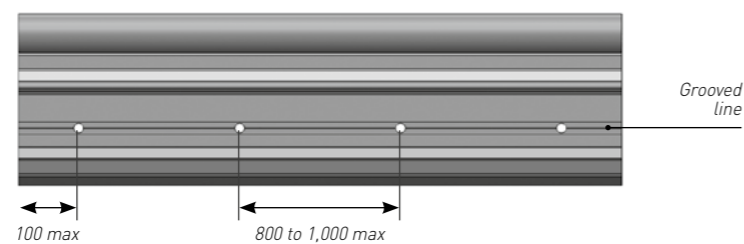

- Fix the endcaps and / or wall returns and / or internal / external angle pieces (make sure that you position the joints) and the aluminium rail with self-tapping screws.

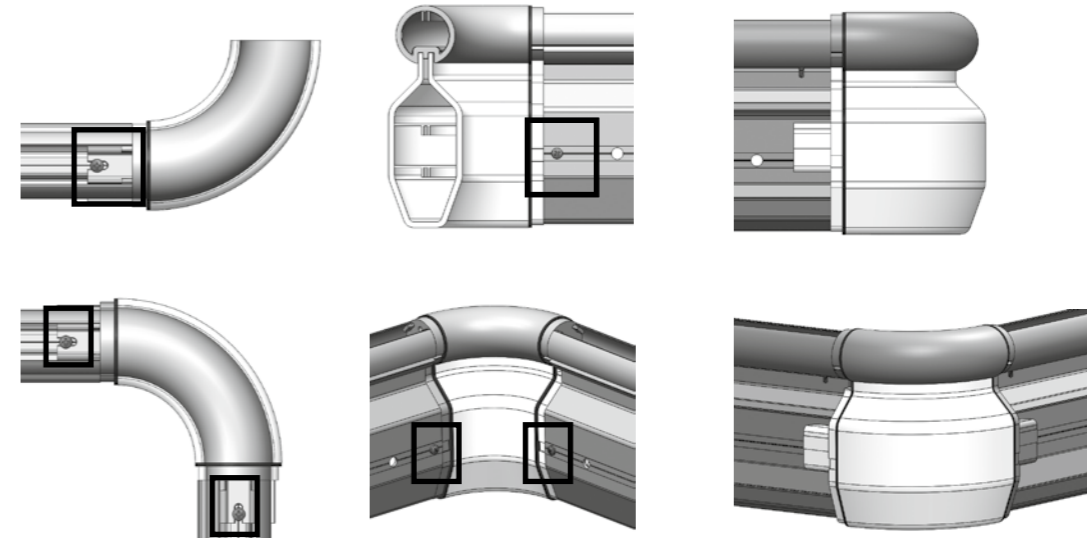

- When joining straight lengths: mark the holes of the joining piece on both profiles (using the piece's outline). Drill the holes (diameter M5) in the grooved line of the aluminium rail and countersink the holes to conceal the screw heads. Assemble the profiles together.

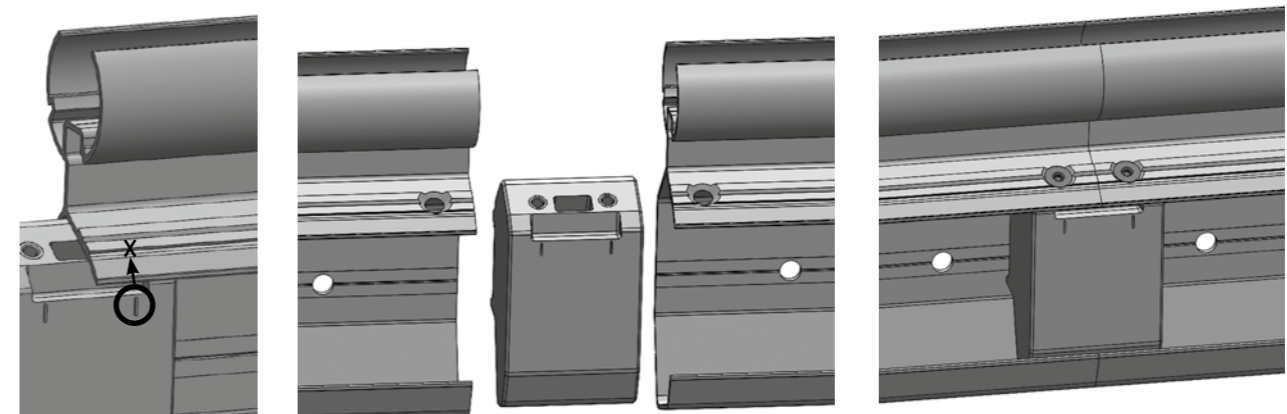

7.3 FIXING ESCORT'DUO AND LINEA'DUO HANDRAILS

- Hold the handrail against the wall, leaving a space of at least 30 mm between the end of the handrail and the edge of the wall. This space means that finishing accessories can be replaced without having to remove the entire handrail.

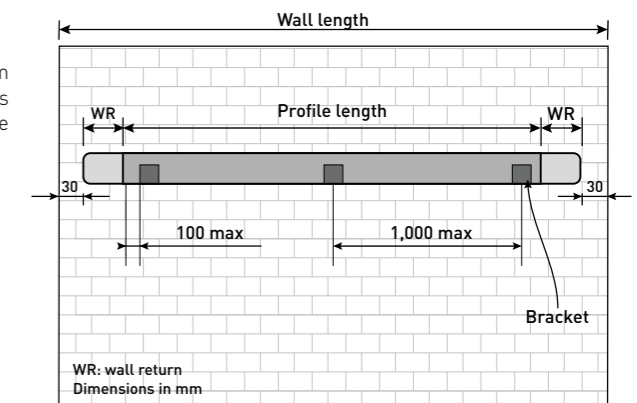

INSTALLING ESCORT'DUO AND LINEA'DUO

- Mark the holes to be drilled for the fixing spacers. For a handrail height of 900 mm (measured at the handrail's upper surface), the drilling height is 800 mm.
- Drill the holes marked on the wall. Insert the plugs.
- Fix the rail with its fixing spacers, starting at each end (the PVC sheaths have not yet been installed as shown in the diagram).

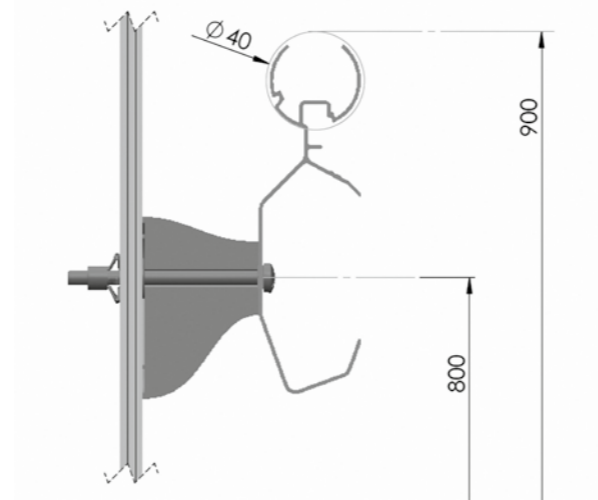

- Clip the "upper" PVC sheath and then the "lower" PVC sheath.

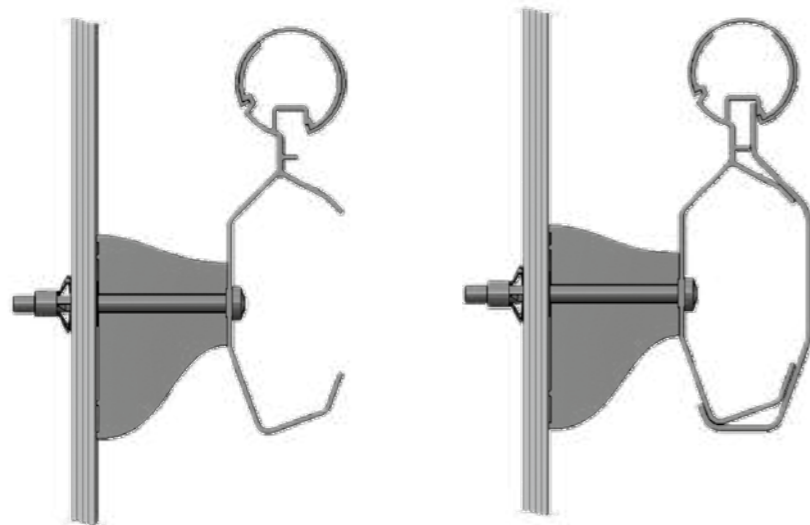

INSTALLING PERFORMER 2

8. PERFORMER 2 HANDRAIL

8.1 PRESENTATION AND ASSEMBLY OF THE DIFFERENT ACCESSORIES FOR PERFORMER 2 HANDRAILS

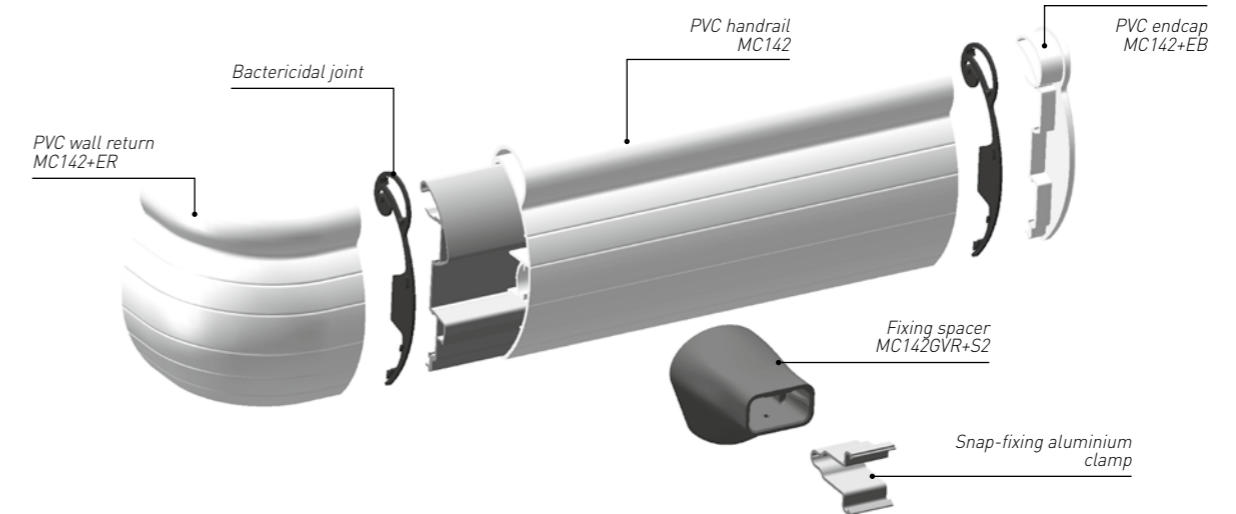

8.2 PREPARING PERFORMER 2 HANDRAIL

Refer to Sections 3.1 and 3.2 on how to calculate the cutting lengths for the profiles. Once the profiles have been cut to length:

If using a wall return:

- Begin by placing the wall return and the bactericidal joint on one side of the aluminium profile.
- Check that the wall return is perpendicular to the aluminium profile before fixing.
- Attach the wall return using a 3 mm self-tapping screw in the aluminium profile.
- The self-tapping screw must be positioned 10 mm from the end of the wall return.

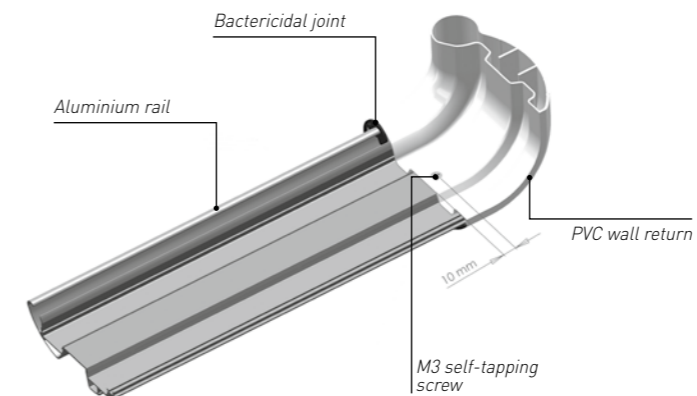

- Clip the PVC profile onto the aluminium rail and slide it against the joint, while making sure that the bosses fit into the slots.
- Ensure that the bosses used to hold the joint in place are properly inserted in the accessory slots.

INSTALLING PERFORMER 2

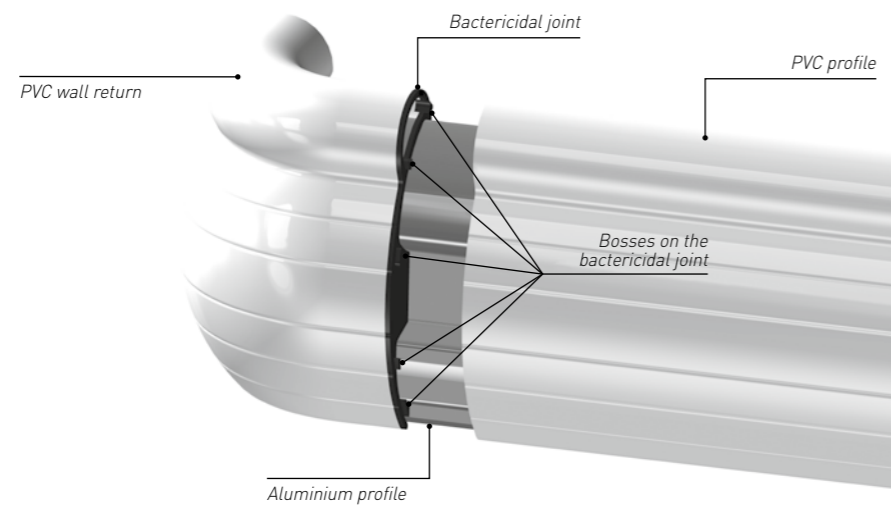

If using an endcap:

- Begin by placing the endcap and the bactericidal joint on one side of the PVC profile.
- Check that the endcap is perpendicular to the PVC profile before fixing.
- Attach the endcap using a 3 mm self-tapping screw in the PVC profile.
- The self-tapping screw must be positioned 5 mm from the edge of the endcap.
- Slide the aluminium rail into the PVC profile.

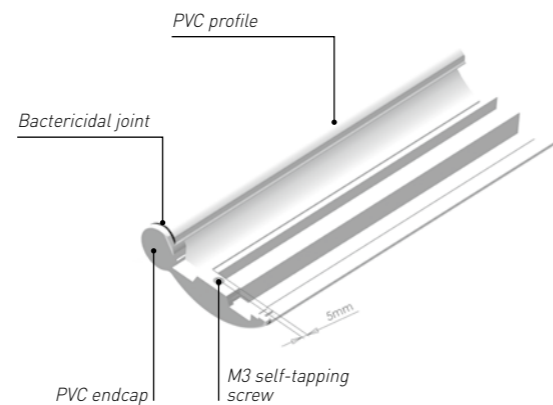

- Ensure that the bosses used to hold the joint in place are properly inserted in the accessory slots.

INSTALLING PERFORMER 2

On the other side of the rail:

- Place the joint and the required accessory (endcap or wall return) on the other side of the rail and fix the accessory (according to the specific procedure for the accessory above).
- Lock the assembly using a self-tapping screw at both ends of the aluminium profile.
- Finally, fit the snap-fixing clamps to the aluminium profile.

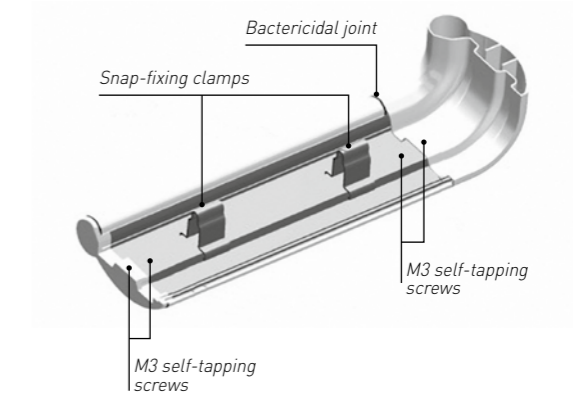

Two lengths of PERFORMER 2 handrails can be joined with a single piece that aligns and secures the joint. The jointing piece is fixed to the aluminium rail with two 5 mm socket screws.

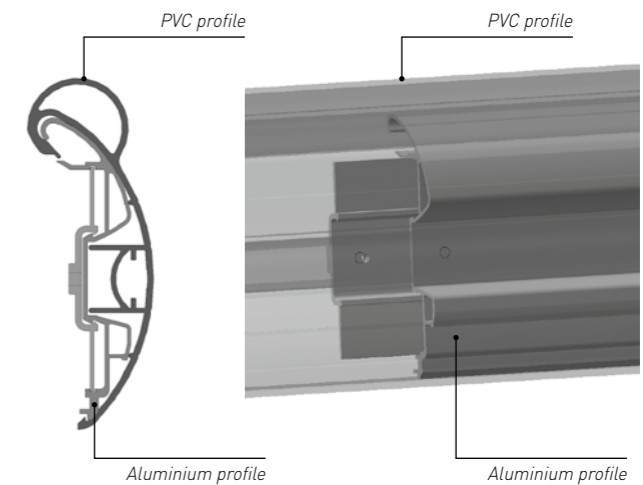

In case of a PERFORMER 2 handrail, offset the ends of the aluminium and PVC profiles to conceal any clearances.

8.3 FIXING PERFORMER 2 HANDRAILS

- For a handrail height of 900 mm above the floor, position the fixing spacers at a height of 822 mm (for MC142GVR+S2 spacers).
- Mark out the wall using a pencil and rule, or a laser.
- Position the outer spacers at 150 mm from the edge of the wall (as close as possible to the wall return).

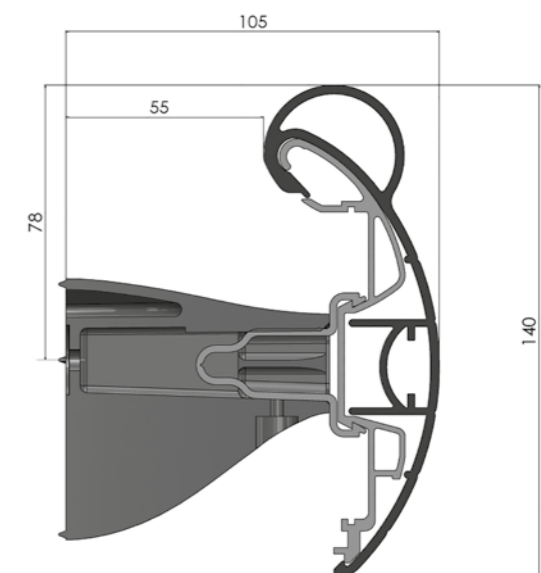

INSTALLING PERFORMER 2

- Drill and plug the wall, hold the spacer against the wall, insert the screw and then tighten.
- Set the spacers every 800 mm (600 mm in heavy-traffic areas).

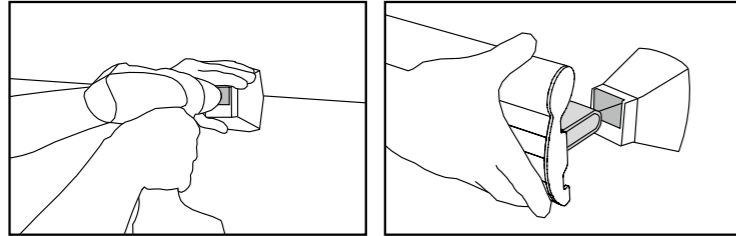

- Insert the snap-fixing clamps in the spacers.
- Adjust the gap between the wall and the handrail as required and secure in place with the self-tapping screw.

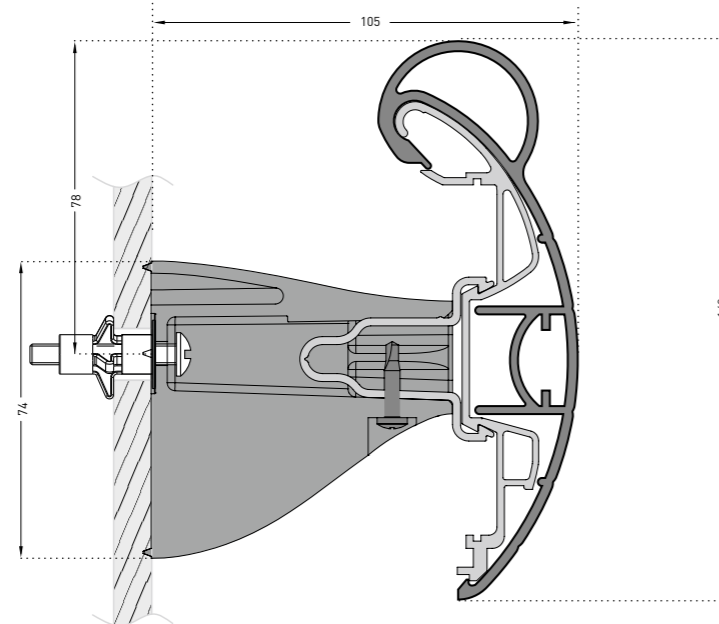
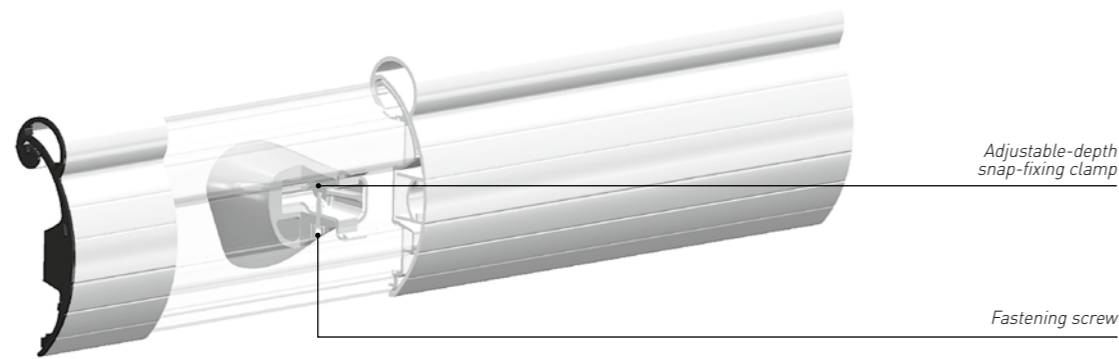

TECHNICAL SOLUTIONS

9. INTERNAL, EXTERNAL AND MADE-TO-MEASURE ANGLE PIECES

Table summarising the angle pieces available for SPM handrails:

HANDRAIL	INTERNAL ANGLE PIECE	EXTERNAL ANGLE PIECE	MADE-TO-MEASURE ANGLE PIECE
ESCORT	Available	Available	Available from 90° to 165°
STARLINE	Available	Available	Available from 90° to 160°
LINEA TOUCH	Available	Available	Available from 90° to 160°
PERFORMER 2	Unavailable	Available	Unavailable
ESCORT DUO AND LINEA DUO	Available	Available	Unavailable

Each angle must be accurately measured beforehand with a compass.

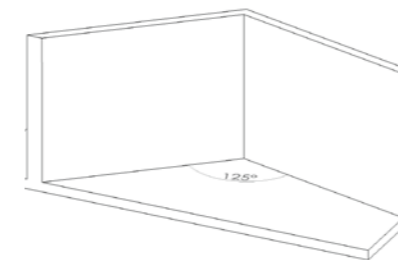

Internal angle of 125°

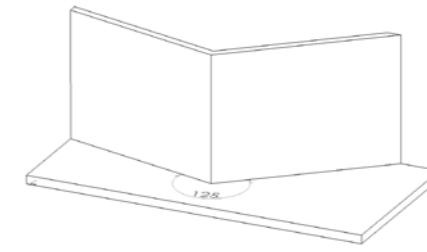

External angle of 125°

You are advised to use the following procedure to obtain a perfect fit between the handrail and the angle piece, while ensuring that the angle piece is centred over the corner of the wall:

- Mount the handrail onto one end of the angle piece and tighten the fixing screw (or drill and pop-riev for STARLINE and PERFORMER 2 handrails).
- At the other end of the angle piece, insert a 500 mm length of handrail. This length will be used as a template and should not be permanently attached to the angle piece.
- Mount the brackets on the handrails (with two brackets on the template).
- On the first wall section, mark out the mounting height for the handrail.
- Position the assembly against the wall over the height marks and then hold the brackets on the template against the opposite wall. This method makes it easier to keep the assembly steady.
- Mark the bracket fixing holes on the wall (using a spirit level to check that the assembly is horizontal).
- Rest the assembly on the ground and remove the template.
- Drill and plug the first wall section (i.e. the handrail side, not the template side).
- Assemble and fix the handrail and its brackets to the angle piece in place of the template.
- Position the assembly against the wall according to the marks drawn on the wall.
- Fix the first section of the handrail to the wall (one person fixes the handrail, starting with the end brackets, while the other person supports the other handrail section to avoid breaking the angle piece).

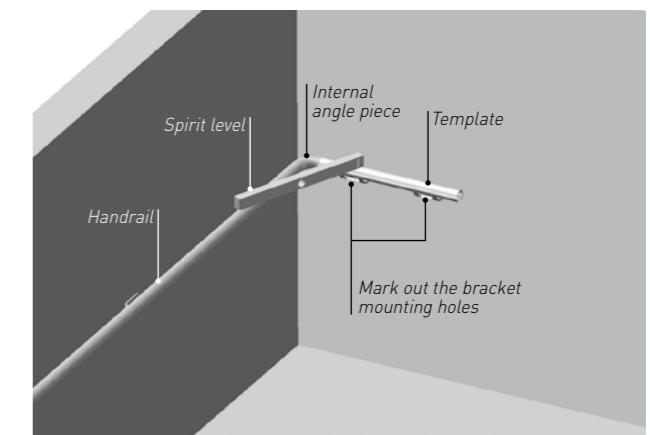

- Mark out the fixing holes for the handrail that has not yet been attached.
- Once the holes have been marked, remove the assembly from the wall by unscrewing the brackets for the handrail fixed earlier.
- Drill and plug the second wall section.
- Reposition the assembly and fix the first handrail section and then the second handrail section onto the wall.

TECHNICAL SOLUTIONS

10. ADJUSTMENT SHIM FOR ESCORT, STARLINE, LINEA TOUCH AND TOUCH+ HANDRAILS

If the wall surface is uneven, the brackets can be adjusted against the wall using 10 mm thick adjustment shims. These shims are fitted behind the brackets.

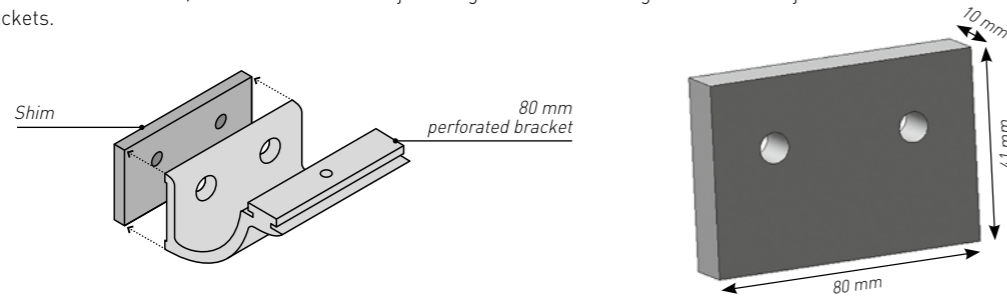

11. LAYING HANDRAILS WITH THE SERVICE DUCT KIT

Where a service duct has been installed, a removable handrail section may be required to provide easier access to the duct.

The distance between the brackets must not exceed 1,200 mm. The handrail must be located in a low-impact area. The strength of the wall fixings must be suited to the forces exerted.

Service duct kit for ESCORT handrails

For ESCORT handrails, the service duct kit is created in-situ (by cutting the profile to the dimensions of the access cover using 45° mitred cuts). If the removable ESCORT handrail section is longer than 1,100 mm, a quick-removable bracket will need to be fitted to the access cover. Quick-removable brackets come with an assembly wedge that can be clamped into the groove in the aluminium rail with a 3 mm Allen key.

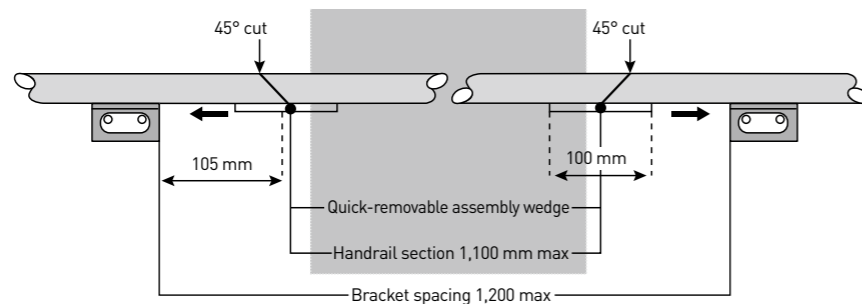

Rapid'Access® articulated link: adaptable angle piece to provide access to service ducts. This accessory replaces the assembly wedge on one of the sides and allows the handrail to be partially removed.

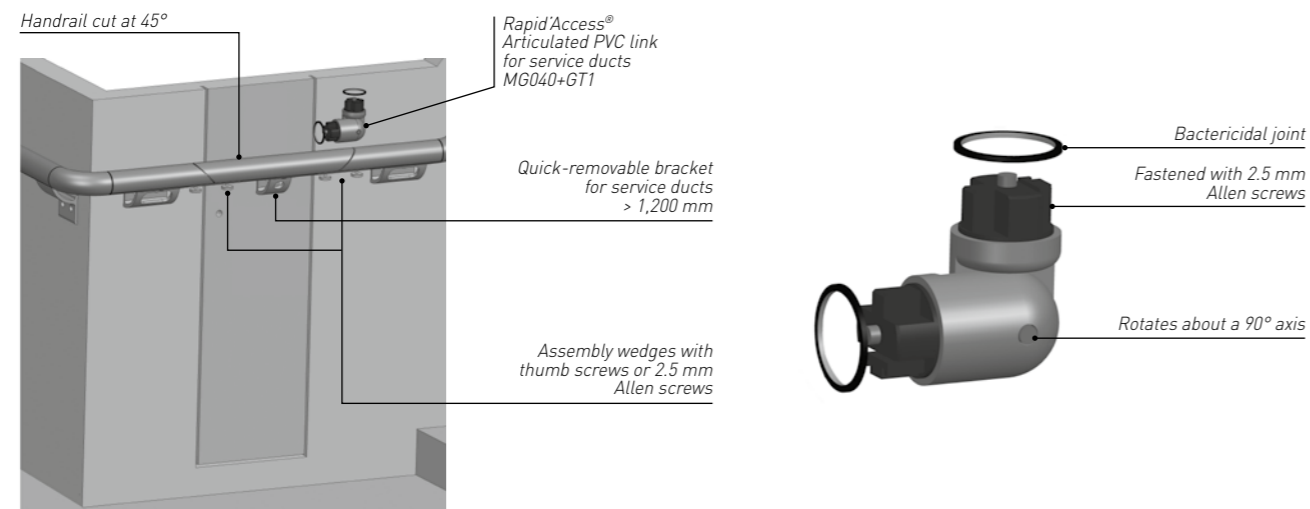

TECHNICAL SOLUTIONS

Service duct kit for LINEA TOUCH handrails

- The service duct kit is created in-situ by cutting the profiles at 45° and positioning the sliding assembly wedges.
- Where the removable LINEA TOUCH handrail section is longer than 1,100 mm, a quick-removable bracket will need to be fitted to the access cover.
- Quick-removable brackets come with an assembly wedge that can be clamped into the groove in the aluminium rail with a 2.5 mm Allen key.

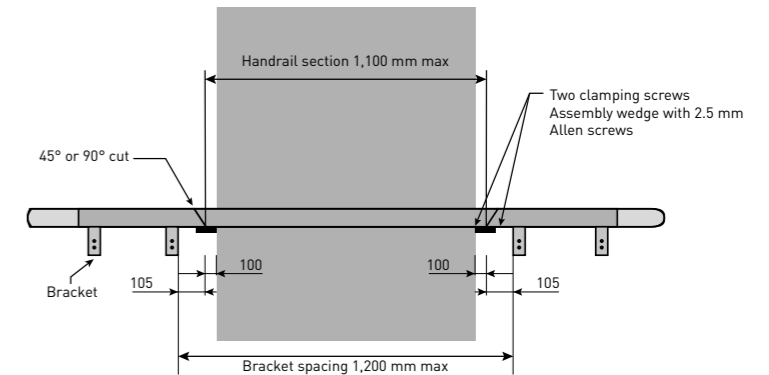

Service duct kit for ESCORT DUO and LINEA DUO handrails

The service duct kit is created in-situ by cutting a section of wall protection handrail to the length of the access cover. The cut must be 90°. Then position the elements according to the dimensions shown in the drawing opposite.

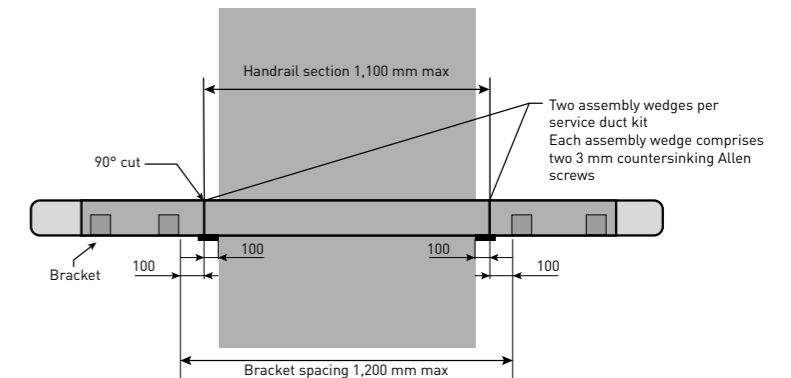

- Mark the holes of the assembly wedges (by using the wedges' outline). Drill the holes (diameter M5) in the grooved line of the aluminium rail and countersink the holes to conceal the screw heads. Assemble the profiles together.

- The upper PVC profile is the same length as the aluminium profile.

- The lower PVC protection rail measures at least 60 mm more than the aluminium profile to allow access to the screws for removal.

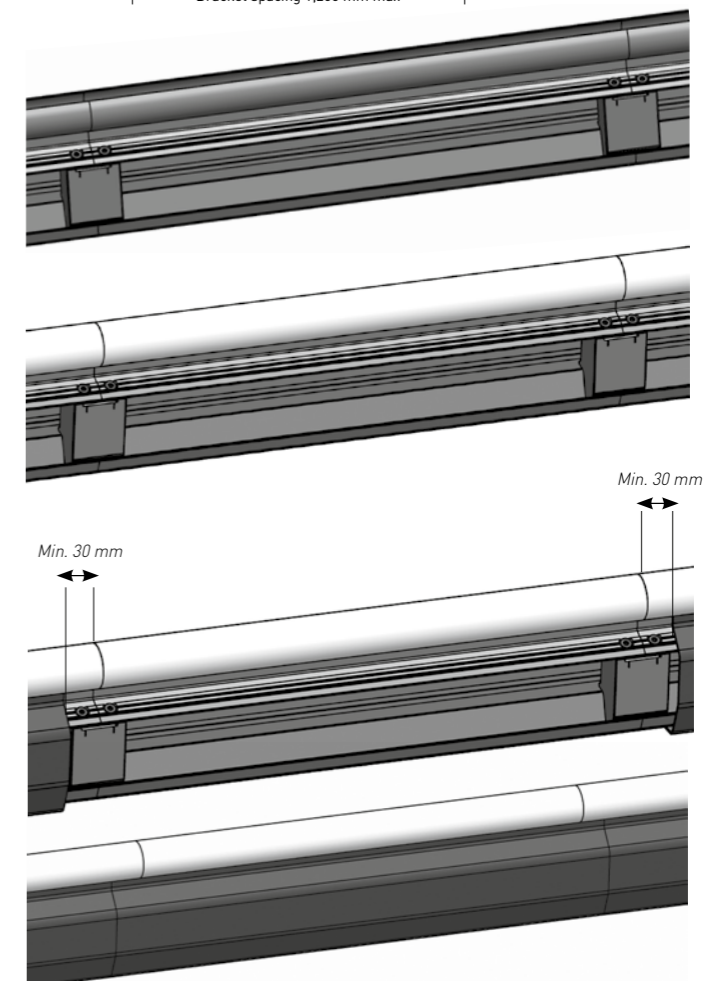

TECHNICAL SOLUTIONS

Service duct kit for STARLINE handrails

For STARLINE handrails, SPM can provide a ready-to-install kit in lengths up to 1,100 mm (other lengths on request).

- Where the removable STARLINE handrail section is longer than 1,100 mm, a quick-removable bracket will need to be fitted to the access cover.
- Quick-removable brackets come with an assembly wedge that can be clamped into the groove in the aluminium rail with a 3 mm Allen key.

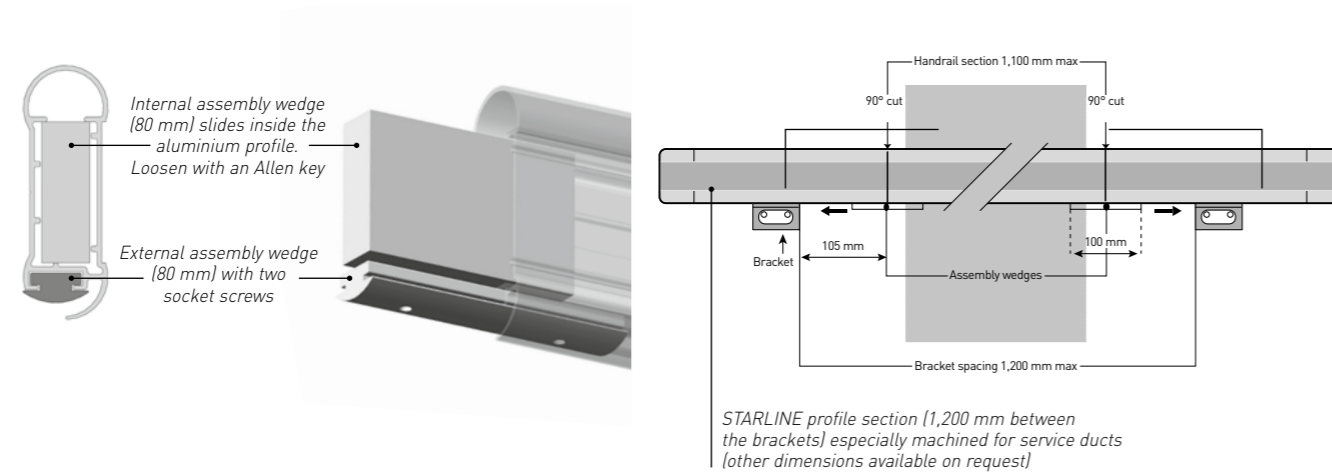

TECHNICAL SOLUTIONS

- When curved handrails are installed in a run with straight handrails, the curved section is terminated with straight lengths at each end to create a perfect junction.

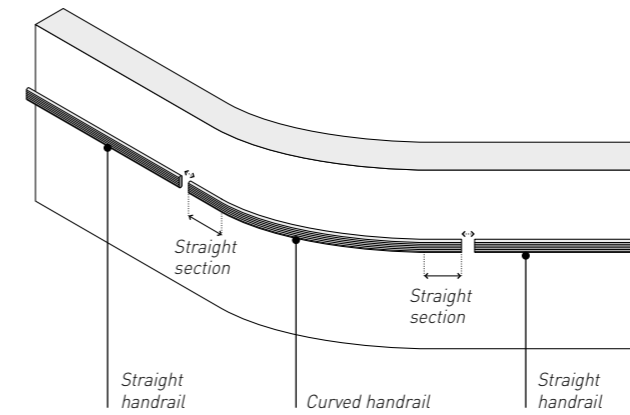

13. MAINTENANCE

- Do not leave products exposed to sunlight. Excessive increases in temperature could lead to changes in colour and/or deform the product.
- The following products are recommended for cleaning:
 - Ammonia
 - Ethanol
 - Isopropyl alcohol
 - Essence F cleaner
 - Standard cleaning products, such as Bioquell and Anios
- Products MUST NOT BE CLEANED with a scouring pad, such as a Scotch-Brite pad.

DO NOT USE:

- White spirit
- Acetone
- Petrol
- Paint thinners

It is essential to use solvents that do not leave any greasy or dry residue. If using non-recommended products, test on an offcut. Reactions may differ depending on the colour of the product and the solvents used.

12. INSTALLING CURVED HANDRAILS

Curved handrails can be installed using **ESCORT, STARLINE, LINEA TOUCH and TOUCH+** handrails.



- Important: for curvature radii below 2 metres, curved handrails are wall-mounted using one of the two brackets below.

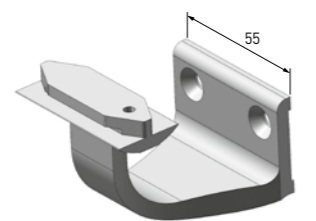

55 mm bugled bracket
-specific curving-
ESCORT and STARLINE
MG040ANO+S3C or MC090ANO+S3C

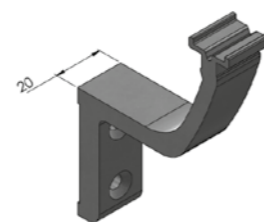

20 mm refined bracket
LINEA TOUCH
ME000ANO+S1

Service Export

Tel : + 33 (0)5 34 39 41 00
Email : export@spm.fr

spm-international.com / follow us



SPM international S.A.S.

16 rue Isabelle Eberhardt
CS 92083 - 31019 Toulouse Cedex 2 -
France
Tel : +33 (0)5 34 39 40 00

**PANELS
HANDRAILS
PROTECTION RAILS
CORNER PROTECTION**

Committed to sustainable development



A company of **Gerflor**

